

S6-S7 CHOICE OF SUBJECTS 2024-2026

Subject information sheets

ART 4.....	3
BIOLOGY 2.....	5
BIOLOGY 4.....	6
CHEMISTRY.....	8
CLASSICAL STUDIES.....	9
DIGITAL ART (SPECIALISED ART LAB).....	10
DRAMA (THEATRE STUDIES AND DRAMA).....	12
EDUCATION FOR SUSTAINABLE DEVELOPMENT.....	13
ECONOMICS.....	14
GEOGRAPHY 2.....	15
GEOGRAPHY 4.....	16
HISTORY 2.....	18
HISTORY 4.....	20
HISTORY OF ART.....	22
ICT.....	24
INTRODUCTION TO ECONOMICS.....	25
L1A DEUTSCH L1, VERTIEFUNGSKURS.....	26
L1A ENGLISH L1 ADVANCED.....	27
L1A FRANÇAIS LANGUE 1 APPROFONDISSEMENT.....	29
L1A PORTUGUÊS LÍNGUA 1 APROFUNDAMENTO.....	30
L2A DEUTSCH L2, VERTIEFUNGSKURS.....	32
L2A ENGLISH L2 ADVANCED.....	34
L2A FRANCAIS LANGUE 2 APPROF.....	36
L3 DEUTSCH.....	37
L3 ENGLISH.....	39
L3 ESPAÑOL LENGUA 3.....	40
L3 FRANÇAIS LANGUE 3.....	42

L3 ITALIANO.....	43
L4 DEUTSCH.....	44
L4 ENGLISH.....	46
L4 ESPAÑOL LENGUA 4	47
L4 FRANÇAIS LANGUE 4	49
L4 ITALIANO.....	50
L4 PORTUGAIS LANGUE 4	51
L5 CHINESE.....	52
L5 DUTCH	53
L5 ITALIAN	54
L5 LËTZEBUERGESCH	55
L5 MODERN GREEK NEA EΛΛΗΝΙΚΑ.....	56
L5 PORTUGUESE.....	57
L5 SPANISH.....	58
LABORATORY BIOLOGY	59
LABORATORY CHEMISTRY	60
LABORATORY PHYSICS.....	61
LATIN.....	62
MATHEMATICS.....	63
MATHEMATICS 3.....	63
MATHEMATICS 5.....	64
ADVANCED MATHEMATICS	64
MUSIC 2	66
MUSIC 4	67
PHILOSOPHY.....	69
PHILOSOPHY 2.....	69
PHILOSOPHY 4.....	70
PHYSICS	72
POLITICAL SCIENCE.....	73
SOCIOLOGY	74
SPORT	75
TECHNICAL DRAWING	76

ART 4

Optional course
4 periods per week

In S6 and S7 the art 4 period course is a valuable opportunity for students to develop their individual creative potential through personal research and investigation and through project-based practical work.

Objectives

The subject Art in the European schools means **The Visual Arts**. Visual arts contain the complex process of perception, reflection and interpretation of the world around us and result in the creation of images. This process and the resulting products are the main working areas of the subject art.

Content

When choosing art as a 4-period option in S6 and S7 the student may opt to do the practical art exam at the baccalaureate. All exams in this cycle follow the baccalaureate exam format with four regular art lessons of preparation time. In S6 the set time for the final work is 5 periods (225 minutes), in S7 it is 5 hours (300 minutes). The projects during the year also follow the structure of the required working process: research in the art book, separately presented preparatory work, final work, and written statement. In year 6 the teacher decides on the themes in collaboration with the students. The projects proposed on these themes cover different art areas and techniques. An overview of the art of the 19th and 20th centuries and of contemporary tendencies is given within years 6 and 7.

Reference to previous art periods and styles is possible whenever necessary. In the 4-period art option, art history and theory are taught to inform practical art making and not as a separate subject. In year 7 the content follows the requirements of a given year theme common to all European schools that will also be the theme of the baccalaureate exam in art. This theme is chosen from the proposals sent in from all art teachers of S6/7 in the European schools.



Artworks of S7 students. Year theme: Animals and Us

Assessment

A mark: portfolio (results of practical projects), workbook, formative assessment

B mark: set exam (one per semester) that follows the format of the baccalaureate exam.

The exam is practical and there are three main areas of assessment:

- **preparatory work (40%)** shows depth of research, a range of ideas, selection, and development of one or more chosen possibilities leading clearly to a final work.
- realisation of the **final work (50%)** which will be assessed on the originality and sophistication of the composition, the technical competence in the media chosen and the appropriateness of the response.
- **final written commentary (10%)** which demonstrates a critical reflection on the making of the final work, shows the student's understanding of the year theme.

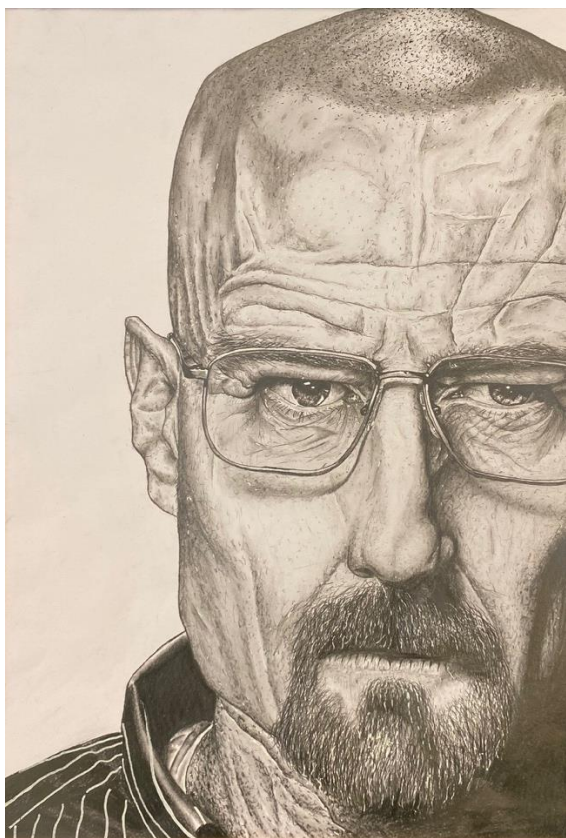

Artworks of S6 students. On the left "Facial Expressions". On the right "Biomorphic Forms"

Contact

For further information, please contact your Art teacher or the Art coordinator, Mr Christos Koutsoukis (christos.koutsoukis@teacher.eursec.eu)

BIOLOGY 2

Compulsory course¹
2 periods per week

This course is open to all students. Students considering higher studies in science are recommended to take the Chemistry option course as well.

Objectives

- Content topics are used to learn general key competences, to acquire specific scientific and mathematical competences, and to connect across disciplines with cross-cutting concepts, as modelled in the Next Generation Science Standards from the United States National Science Teachers Association
- The specific scientific competences to be acquired by students are: knowledge and comprehension, application, analysis, practical work, digital and information competences, communication (oral and written), teamwork.
- Certain cross cutting concepts are shared by all mathematics and science: patterns, cause and effect, quantification, representing data, scale, proportion, and quantity, systems and system models, energy and matter, structure and function, stability and change, history and nature of science.
- Globally, students should develop awareness of the environment and learn to act as responsible citizens with respect to it.

Content

In year 6

- Food, nutrition, and health - what we eat: exploring food production, distribution, consumption, processing, politics, nutrition sciences, marketing, and personal health
- Personal and public health - how we stay healthy, as individuals and groups: the human immune system, disease as a population phenomenon, and the links between disease outbreaks and the natural world
- Brain and mind: learning, memory, and consciousness - how we think, learn, remember, and feel

In year 7

- Genetic manipulation - thinking through our increasing power to manipulate and control the genomes of species including our own.
- Climate change and biodiversity - how our planet's climate is changing, and what it means for us and all living things on Earth.
- Project: an opportunity to explore one of this course's themes in depth.

Assessment

Two 1 period tests each semester, other short tests, presentations by students are arranged during the semester.

Contact

For further information, please contact your Biology teacher.

¹ Biology 2 periods is compulsory only for those pupils who do not choose a science from the optional subjects. It is not available for those pupils choosing Biology as an option, but is a possibility for those pupils who choose Chemistry and/or Physics.

BIOLOGY 4

Optional course
4 periods per week

Pupils choosing this option should have been successful in the S4-S5 compulsory course and be prepared to take on a greater degree of complexity in content and approach, including mathematical competences. Students considering higher studies in science are recommended to take the Chemistry option course as well.

Objectives

- The 4-period biology course is designed for pupils with an interest in studying the science at a more advanced level, whether for personal interest or as preparation for university studies in Biology, Medicine, or other scientific disciplines Biochemistry, Agriculture, Physiotherapy, Neuroscience, Pharmacology, Food science, Environmental science, Sport science, Veterinary science, Psychology,
- Content topics are used to learn general key competences, to acquire specific scientific and mathematical competences, and to connect across disciplines with cross-cutting concepts, as modelled in the Next Generation Science Standards from the United States National Science Teachers Association
- The specific scientific competences to be acquired by students are: knowledge and comprehension, application, analysis, practical work, digital and information competences, communication (oral and written), teamwork.
- Certain cross cutting concepts are shared by all mathematics and science: patterns, cause and effect, quantification, representing data, scale, proportion, and quantity, systems and system models, energy and matter, structure and function, stability and change, history and nature of science.
- Globally, students should develop awareness of the environment and learn to act as responsible citizens with respect to it.

Content

In year 6

- Cell Scale - Cells as the fundamental organising units of organisms. The fundamentals of biochemistry. In-depth study of three crucial aspects of life at the cellular scale: membranes, enzymes, and the central role of ATP in energy transfer.
- Human Scale – How the nervous system coordinates and controls the actions and interactions of vertebrates, including humans. The brain as the location of learning, memory, and consciousness.
- Time Scale – Consideration of biological phenomena over two time scales: the scale of individual reproduction and inheritance, comprising molecular, Mendelian, and chromosomal genetics and the scale of evolution, comprising an enriched understanding of the action of natural selection, and the construction of evolutionary phylogenies.
- Planet Scale – An introduction to ecological theory, practice, and modelling. A grounding in population ecology. Repercussions of human effects on ecologies at scales from local to global, and possible solutions to anthropogenic problems.

In year 7

- Cell Scale – Building on the basics of cell biology give an overview of the fundamental metabolic pathways common to all cells: ATP and protein synthesis.
- Human Scale – How vertebrates, including humans, defend the integrity of the self against threats from within and without. Disease as a phenomenon of populations, and how it can be combatted through human ingenuity and cooperation
- Time Scale – The recognition that, while DNA provides the information underlying an organism's development, its individual life history is shaped by epigenetic factors. Addition of a mathematical modelling perspective to a population-based understanding of evolution.

- Planet Scale – pupils add the perspective of ecosystems analysis, modelling energy and matter flows, and apply these models to human issues (e.g., anthropogenic climate change, pollution, sustainable agriculture).

Assessment

There is a three period exam at the end of each semester in year 6 and a 3 hour exam at the end of each semester in year 7 (At the BAC some students can choose to have an oral exam rather than a written if they have sufficient options). Other short tests, practical work with laboratory reports and presentation by students are arranged during the semester.

Contact

For further information, please contact your Biology teacher.

CHEMISTRY

Optional course
4 periods per week

This course is open to all students that have shown an interest in chemistry and have completed the 5th year course, **ideally with a “good” grade or better.** Students should be open minded to be able to apply knowledge and understanding to new situations. It is recommended to students that have a taste for manipulation and for interpreting the results of experiments. The analysis of results implies the **use of mathematical techniques.**

The skills that the chemistry course will develop and consolidate are thus varied and transferable for a broad range of university degrees from accounting to zoology. A chemistry Bac is proof that these skills are present at a high level.

Students must have confidence in their application of mathematical techniques studied in the 6 period mathematics maths course. Even so, the 5 period maths option is not essential for this course, and it is also possible to follow this course, albeit requiring more effort, after following the 4 period maths course in 5th year.

Objectives

- This chemistry course completes and goes into a more in-depth study than the previous years. Experiments, manipulations and the use of the scientific method are at the heart of this course.
- This course offers students a solid base for higher studies in chemistry, medicine, pharmacology and biology. Chemistry is a requirement to study medicine and life science related studies at most universities.
- The course also provides knowledge useful for students interested in physics, engineering, material science and environmental studies. The course aims to make students aware of the complexities of chemistry and its interdependence with other subjects, to develop students' capacity to evaluate objectively the impact of chemistry on social, economic and environmental issues.

Content

In year 6

- Structure of the atom and the periodic table
- Chemical bonds
- Thermodynamics
- Rates of reactions
- Organic chemistry (structure and properties of the hydrocarbons -alkanes, alkenes, alkynes, benzenes)

In year 7

- Chemical equilibria
- Acids and bases (pH, pKa, titrations)
- Electrochemistry (redox reactions, electrolysis, electrochemical cell)
- Organic chemistry (alcohols, aldehydes, ketones, carboxylic acids, lipids, detergents, amines, amino acids, aspirin, mechanisms)

Assessment

At least one long test (1 period) and one 3 period exam each semester.

Contact

For further information, please contact your Chemistry teacher.

CLASSICAL STUDIES

Complementary course
2 periods per week

All students can choose this course. To follow the course of **Classical Studies: Myth and Society** is a sign of taking an independent step: a sign of autonomy, originality and creativity, reaching beyond fashion and conformity, and far from a utilitarian view of education. Knowledge of the ancient world contributes in a decisive and original manner to the development of the key competences for education and for a life-long education.

By attending this course the students will have the chance to understand the impact of antiquity on modern culture, compare modern art (paintings, novels, poetry, theatre, cinema, etc.) to ancient art, and become acquainted with the influence of ancient art forms and ideas on our culture today.

Objectives

Over the course of S6 & S7, students should develop skills in:

- Consulting different sources (archaeology, epigraphy, literary and non-literary texts, images)
- respecting the different nature of each one.
- Recognising and using in a critical way available resources for the ancient world, including digital resources.
- Developing the relations between the ancient languages and other modern languages
- Putting in perspective with nuance and precision the heritage and reception of Antiquity in its different manifestations and modes of expression
- Presenting a research project or analysis giving a personal point of view.

Content

The course of **Classical Studies: Myths and Societies** will take place over a period of two years. Each programme should be covered in the year concerned (S6 and S7). All the topics should be covered but the teacher may:

- a) decide on the way they will be treated
- b) decide the order in which the topics are covered.

6th Year

- Men and Gods: psychological journeys
- Masculine/feminine: sex and desire
- The Mediterranean: travel, exploration, discovery

7th Year

- The gods in the city: religion and belief
- The Tragic Family
- The Mediterranean: conflicts, influences and exchanges

Assessment

6th/7th Years - For the two years, the B mark is the average of two semester tests, each lasting 45 minutes, with an annual total of four tests. Continuous assessments for the A mark (projects, oral presentations, debates, discussions, critical analysis of works of art, etc.)

Contact

For further information, please contact Ms Vasiliki Knitou (vasiliki.knitou@teacher.eurisc.eu).

DIGITAL ART (SPECIALISED ART LAB)

Complementary course
2 periods per week

Objectives

This complementary course gives students the opportunity to develop their potential in more specific areas of visual arts and is based on practical projects. It covers different content than a general art course and can be combined with the Art 4 period option.

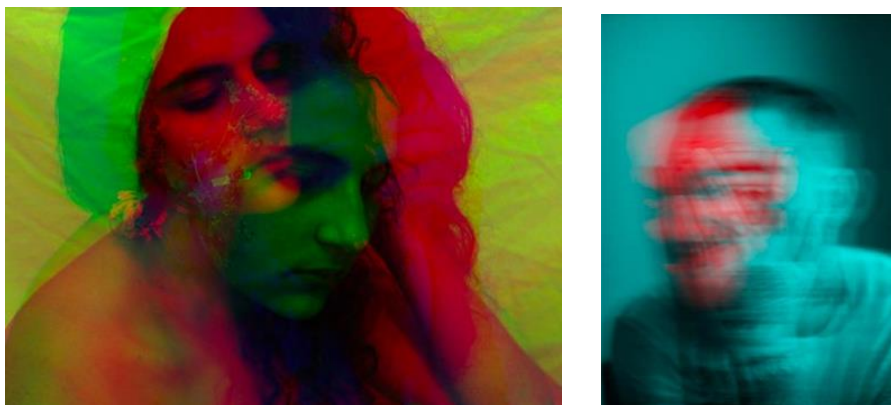

Work of S7 students inspired by the photographer Pep Ventosa. Working with layers

Content

The content of this course helps the students to learn contemporary computer-based techniques of image production. It is a practical course in photography and computer art that is mostly based on the programs of the Adobe Creative Suite (Photoshop, Illustrator, In Design, Lightroom). The structure for the infographics course in S6 is capturing reality through photography and film, and in S7 re-creating reality through computer art and design.



Work of S7 students inspired by the artist David Hockney

Assessment

A mark: evaluation of the practical work and of the participation in class (focus and attention; active participation and quality interventions; regularity and consistency in the work; signs of imitative and autonomy).

B mark: portfolio of work done during the semester (the teacher may decide to add a verbal presentation and interview as part of the assessment).



Draw on a photograph



Create a work inspired by Surrealism

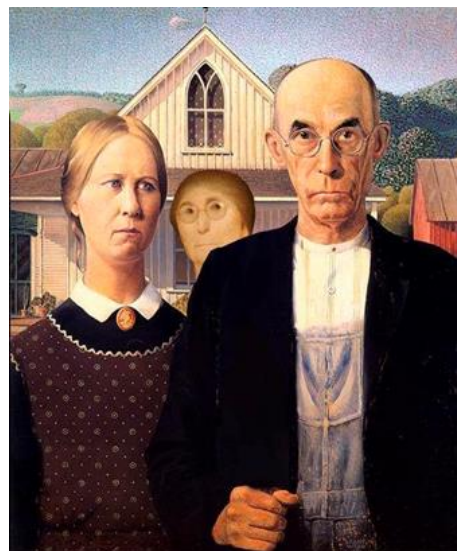
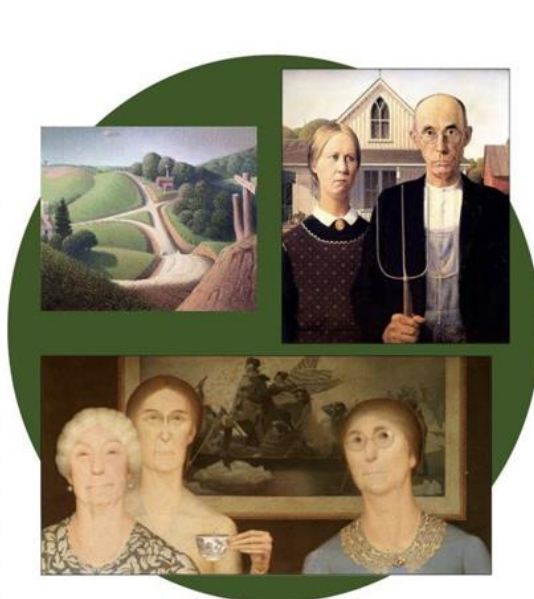

Digital montage of S7 student on the theme: Edit a famous artwork. The student used three artworks of Grant Wood (Adobe Photoshop) and remade the original one.

Contact

For further information, please contact the Art coordinator Mr Christos Koutsoukis (christos.koutsoukis@teacher.eursec.eu).

DRAMA (Theatre Studies and Drama)

Complementary course
2 periods per week

Objectives

The Drama and Theatre Studies complementary course for the 6th and 7th years is an addition to the 2 period courses currently on offer to the 6th and 7th years. It mixes both academic study of one of our principal artistic forms with practical work. In this it resembles the complementary course of Art in that it gives students a possibility to study a discipline and produce their own work within that discipline.

Drama both as a practical experience, an academic discipline and to understand the subtleties of Drama as a spectator.

Highlights:

- Analyses of authentic texts (reviews, writings by playwrights, plays)
- Reports on research work, including digital research work
- Journals and diaries (as a theatregoer, creative process).
- Practical exercises throughout the year:
 - Targeted application of acting techniques
 - Solo or group improvisations
 - Expressive reading, voicing and stage positioning of authentic theatrical texts
 - Constructions of situations
 - Stage design proposals
 - Staging of authentic theatrical texts

Content

Theory	Practice
<p>1. Critical Diary</p> <p>A record of between 3 and 6 theatrical plays that the student has seen, with specific focus on Acting, Medium and Direction</p>	<p>1. Improvisation and Workshop</p> <p>Developing practical drama skills (Observation, response, performance, evaluation etc.)</p>
<p>2. Textual Criticism</p> <p>Analysis of a range of drama texts focusing on their dramatic and theatrical elements</p>	<p>2. Special Study</p> <p>A documented response to a practical theatre project such as a school play</p>
<p>3. Study of core texts</p> <p>At least two texts to be studied in full from a range of dramatic contexts and time periods</p>	<p>3. Assessed performance</p> <p>An assessed group performance piece from an existing and a devised script</p>

Assessment

Assessment will be through a mixture of assessed performance, critical theatre diary and textual criticism.

Contact

For further information, please contact Ms Laurence Beltran (laurence.beltran@teacher.eursc.eu)

EDUCATION FOR SUSTAINABLE DEVELOPMENT

Complementary course
2 periods per week

The European Schools recognise the importance of education for a successful green transition. It is crucial to ensure learners develop competences (knowledge, skills and attitudes) to think, plan and act for our planet and for a transition to a fairer, greener economy and society.

This complementary course is intended for all pupils interested in understanding the transdisciplinary and global dimension of environmental issues and its relation to sustainable development. Pupils choosing this course should have a strong personal motivation to engage in a systemic approach to environmental issues.

This course is suited to all pupils. No prerequisite and associated courses are required to complete this course. The contents in sciences and humanities are affordable for all pupils as well as the references to specific literature in the field. However, at the end of the course, pupils will attain a solid background in this topic, which will be of a particular benefit for pupils who plan to study environmental issues and the green transition in post-secondary education.

The main objective of the course is to give the keys to a **systemic, prospective, and collective understanding of a sustainable world**. The course incorporates individual and collective responsibility to understand the necessary changes for the construction of a sustainable world. The course is spread over the two years, s6 and s7, according to a chronological and a differentiated content.

- The **programme for s6** focuses on the work of training and acquiring current concepts in the contribution of science, sustainable development, anthropocene, humanities and social sciences. Multiple approaches to education for a sustainable world will be emphasized through individual and team activities, field trips, etc.
- The **programme for s7** will focus on the completion of a final project which should mobilise all the dimensions studied in the previous year. In order to reinforce personal and civic engagement but also to support the pupils' entrepreneurial competences, the format of the final project will be left free and open. Suggestions and examples are provided in the syllabus document.

Contact

For further information, please contact Ms Magdalena Rodzinka ([magdalena.rodzinka@teacher.eursec.eu](mailto:magdalenarodzinka@teacher.eursec.eu))

ECONOMICS

Optional course
4 periods per week

Objectives

- To have a general knowledge about the functioning of life in modern society.
- To develop an enquiring approach to investigation and problem solving.
- To make the transition from descriptive to analytical economics.
- To develop both theoretical and applied approaches to the subject.
- To develop critical and creative skills in the areas of selection, comparison and evaluation.

Content

6th Year

Theoretical and practical studies on the behaviour of firms and markets, the circular flow of income and an introduction to macro-economic models.

7th Year

Government control of the economy, unemployment, inflation, economic growth, trade cycles, international trade and money.

Assessment

6th Year

One three period examination at the end of each semester for the B mark.

Continuous assessment for the A Mark.

7th Year

One three-hour examination at the end of the first semester for the B mark.

Continuous assessments for the A mark.

A final Baccalaureate examination: a three-hour written paper

Contact

For further information, please contact your Economics teacher or the Economics coordinator, Mr Lars Thuesen (lars-naesgaard.thuesen@teacher.eursec.eu).

GEOGRAPHY 2

Compulsory Course²
2 periods per week

Objectives

This course will cover a wide range of knowledge, skills and attitudes as applied to the major themes of Human and Physical geography.

The course provides only a limited level of preparation for geographical and related courses at university level.

Content

The Sixth Year programme considers four major themes:

- Topic 1: The challenge of development (What is development? What are the obstacles to development? Who are the key players and institutions? Spatial variations in development at different scales; Approaches to development solutions and strategies)
- Topic 2: The opportunities and threats of globalisation (What is globalisation? What are the causes of globalisation? What are the opportunities and threats of globalisation? Alternative views of globalisation)
- Topic 3: The environment and climate change (hazards, risk, vulnerability, disasters)
- Topic 4: Project work

The seventh year consists of following topics:

- Topic 1: Europe and the EU (borders, identity, values, the EU structure)
- Topic 2: Natural environment of Europe (relief, climate, challenges and opportunities related to climate)
- Topic 3: Europeans (population, demographic evolution, migration, ageing population)
- Topic 4: Economic sector in change (agriculture, manufacturing, services: tourism, transport, regional inequalities in the EU)

Assessment

In Year 6

The 'A' Grade is based on written assignments set by the teacher as well as oral participation in class.

The 'B' Grade is based on four tests set at regular intervals throughout the year.

In Year 7

The 'A' Grade is the same as in year 6.

The 'B' Grade is based on four 'Pre-Bac' examinations, which are taken at regular intervals throughout the year. There is also the option of taking a 20-minute oral examination in the summer.

Contact

For further information, please contact your Geography teacher or the Geography coordinator, Ms. Magdalena Rodzinka (rodzinma@teacher.eursec.eu).

² This course is compulsory unless Geography is chosen as 4-period option.

GEOGRAPHY 4

Optional course
4 periods per week

Geography is not only up-to-date and relevant, it is one of the most exciting, adventurous and valuable subjects to study today. So many of the world's current problems boil down to geography and need the geographers of the future to help us understand them.

Choosing 4 period geography can open the doors to a university degree, either specifically in geography or by combining geography with other bac subjects to gain a place on a degree programme in another subject. A baccalaureate grade in geography is recognised for its academic 'robustness' and, most importantly, it also helps young people into the world of work.

We know this is true because so many employers prize the knowledge and skills that studying geography can provide, be it knowing how the world works, planning research and report writing, working in a team, using new technologies and communication skills – and much more. You will find geographers working in a wide range of jobs, from the city to planning, working in the environment to travel and tourism, or in international charities or retail.

A student of geography should be someone who: a) has an interest in current affairs; b) wants to learn more about societies, environments, landscapes and places in our world; c) wants to have sufficient knowledge and understanding in order to make informed decisions about factors that affect the earth and its peoples; d) wants to learn and develop a wide range of skills for use in further education and in the workplace.

Objectives

The course will cover a wide range of knowledge, skills and attitudes as applied to the major themes of Human and Physical Geography. The course will provide a good base for those interested in studying geography and related courses such as economics, environmental studies and sociology at university level.

This course aims at providing useful knowledge and methods to understand contemporary events and the world's diversity.

Content

The **Sixth Year** programme covers the fields of Physical, Human and Economic Geography, using case studies from different world regions.

Sixth Year:

- Physical geography & human activity
 - processes shaping the landscape
 - natural hazards
- Natural resources (distribution, use of resources, flows & trade, conflicts)
- The complexity of a global world
 - Development: a world with inequalities
 - What is globalisation?
- **Fieldwork** (definition of aims & objectives, data gathering & processing). We welcome students to travel with the geography department to the Alps to discover the incredible natural landscape!

The **Seventh Year** programme is based entirely on the geography of the European Union.

Seventh Year- The major themes include:

- Natural environment
 - Europe Physical regions (detailed study of the Alpine region)
 - European climates (detailed study of maritime climate)
- European population

- factors influencing population distribution, concentration in urban areas
- population structure
- internal & external migration
- Economy of Europe
 - agriculture (two case studies: one extensive & one intensive farming area)
 - industry (automobile industry, a specific high-tech industry or a science park)
 - services (complexity and importance of the service sector, two case studies)
- European Union Issues & Challenges
 - What is the European Union?
 - Sustainability in the EU (energy policy, CAP)
 - Widening (admission policy, transport policy)
 - Deepening (regional policy)

Assessment

In Year 6

The 'A' Grade is based on exercises set by the teacher as well as oral participation in class.

The 'B' Grade is the result of two end-of-semester examinations.

In Year 7

The 'A' Grade is based on exercises set by the teacher as well as oral participation in class.

The 'B' Grade is the result of a 3-hour pre-BAC examination in January/February. There is also the option to take EITHER a further 3-hour written examination OR a 20-minute oral examination in the summer.

Contact

For further information, please contact your Geography teacher or the Geography coordinator, Ms. Magdalena Rodzinka (rodzinma@teacher.eursec.eu).

HISTORY 2

Compulsory course³
2 periods per week

Objectives

The course aims to:

- provide an opportunity to explore some of the events and trends of the modern world.
- promote a knowledge and understanding of recent history.
- foster a critical and analytical curiosity about the past.
- study and evaluate various historical sources and documents.
- develop logical, structured and supported argument.

The course will address the same questions and topics as the four period option, but in less depth both in terms of subject knowledge and the development of historical skills.

Content

See table below.

Assessment

Yr 6:

- 'A' mark based on oral class work (class work, participation and oral presentation) and homework.
- 'B' mark - two written tests each semester.

Yr 7:

- 'A' mark is calculated on the same basis as in year 6.
- B' mark - one harmonised written test (Prebac) of two period duration (90 minutes) per semester, for a total of 2 written tests per school year.

Contact

For further information, please contact your History teacher or the History coordinator, Mr Christophe Champfaily (christophe.champfaily@teacher.eurasc.eu).

³ This course is compulsory unless History is chosen as 4-period option.

EUROPE AND THE WORLD FROM THE END OF THE 19TH CENTURY TO THE START OF THE 21ST COMPULSORY CORE : EUROPE AND EUROPEANS SINCE 1914

Europe 1914-1945

Year 6 – 2 period
(approx. 24 lessons)

- 1) Europe transformed by the First World War
- 2) Dictatorship and democracy: Europe in the interwar years (1918-39)
- 3) Europe and Europeans in the Second World War

Year 6 – 4 period
(approx. 48 lessons)

Europe since the Second World War

Year 7 – 2 period
(approx. 24 lessons)

- 4) Post-war Europe (1945-1949)
- 5) Eastern Europe, Western Europe (1949-1973)
- 6) Europe from dictatorship to democracy (1974 - 1995)
- 7) Europe in the making (1945 to today)

Year 7 – 4 period
(approx. 45 lessons)

OPTIONAL THEMES

Year 6 – 2 period

3 themes (minimum) x 8 lessons

Year 6 – 4 period

3 themes (minimum) x 15 lessons

6.2A The USA 1898 to 1945	6.4A The USA since 1898
6.2B Culture and Society before 1945	6.4B Culture and Society before 1945
6.2C European colonialism and imperialism from the end of the 19 th century to 1945	6.4C European colonialism and imperialism from the end of the 19 th century to 1945
6.2D Warfare in the 20 th century	6.4D Warfare in the 20 th century
6.2E Women in the 20 th century	6.4E Women in the 20 th century
6.2F Russia and the USSR 1917 to 1953	6.4F Russia and the USSR 1917 to 1953
6.2G Genocide in the 20 th century	6.4G Genocide in the 20 th century

OPTIONAL THEMES

Year 7 – 2 period

3 themes (minimum) x 10 lessons

7.2A Cold War
7.2B China since 1949
7.2C Decolonisation after 1945
7.2D Arab-Israeli conflict since 1947
7.2E The USA after 1945
7.2F The United Nations
7.2G Mass media, popular culture and authority since 1945.

COMPULSORY THEMES

Year 7 – 4 period

3 compulsory themes x 15 lessons

7.4A Cold War and international relations since 1945
7.4B China since 1949
7.4C Decolonisation and independence since 1945

HISTORY 4

Optional course
4 periods per week

History and the past are not the same thing. Nor is history the mere study of the past. History is a process of imaginative reconstruction and interpretation of the past. It is the critical investigation of both the sources that the past has left behind and what historians have written about the past.

Students of 4 period History come to appreciate the relative nature of historical knowledge. Each generation produces history that reflects its own preoccupations and the new evidence that becomes available. History offers opportunities for empathetic understanding, but also develops the capacity for critical distance. It requires students to make comparisons between similar and dissimilar solutions to common human situations, whether they are political, economic, social or cultural. It invites comparisons between, but not judgments of, different cultures, political systems and national traditions.

Studying History is useful for many degrees and career paths – journalism, law, international relations, politics, literature, archaeology, languages and more. Indeed, the University of Cambridge cites History as one of six subjects which can keep your higher education options open (the others being Chemistry, Literature, Mathematics, Foreign Languages, and Physics). It keeps career options open as well. In choosing to study History, the students have the opportunity to attend and participate in debates and conferences as well as participating in extra-curricular trips to enrich their understanding. An in depth study of history can make a significant contribution to a student's future as a European citizen, endowing them with a critical spirit and an awareness of heritage, all so important for the 21st century world.

An interest in politics and current affairs is an advantage as is a willingness to read widely. A good working level of L2 (written and oral) is clearly of benefit, although students will not be formally assessed on their language competence.

Objectives

Students will gain many transferable skills from four period History:

- The historical skills of critical analysis and evaluation not only to historical events, but current world events.
- Through analysing and evaluating historical sources they develop skills of comprehension, comparison & contrast, evaluation & analysis, and synthesis.
- Critical thinking and reasoned arguments through both written essays and oral debate.
- Methodical research and communication skills.

In addition, students:

- Become acquainted with the historical debate and become aware of the provisional aspect of the historical knowledge.
- Gain knowledge and understanding of the past, as well as, of the main trends, themes and concepts of recent history.

The 4-period course is also a good preparation for pupils who will continue their studies in their L2 language.

Above all, students leave the classroom with logical thinking, inquisitive and critically aware minds.

Content

See table above.

Assessment

Yr 6:

- The 'A' mark is based on oral (class work, participation and oral presentation) and written work (tests, source questions, written analysis, essays). A personal research study worth up to 25% of the 'A' mark will be set in one semester.
- The 'B' mark is made up of two semester exams based on the structure of the baccalaureate examination.

Yr 7:

- The 'A' mark is calculated on the same basis as in year 6.
- The 'B' mark is the result of the Pre-Bac part exam in January/February (3 hours). The exam follows the same structure as the final baccalaureate exam.

Contact

For further information, please contact your History teacher or the History coordinator, Mr Christophe Champfaily (christophe.champfaily@teacher.eurasc.eu).

HISTORY OF ART

Complementary course
2 periods per week

Objectives

- An appreciation of art and of art in its historical context
- Help students develop an awareness of their own cultural identity, and foster an understanding and sensitivity towards other cultures
- Knowledge of the development and the characteristics of European civilization
- To know the most important art movements and genres
- To understand and apply the appropriate terminology of Art History
- Develop the ability to describe and analyse art works and designed objects in a structured way
- Develop the ability to critically evaluate sources and use them appropriately for a deeper interpretation and reflection of art works
- Be able to connect art historical knowledge to a perception and understanding of the visual world

Content

The course will be taught in a visual way through sharing and discussing works of art together.

Key periods in the historical development of art and architecture will be studied. These will include:

- Antiquity eg Egyptian, Greek and Roman art.
- Middle Ages eg. Romanesque, Gothic,
- The Renaissance e.g. - Italian and Flemish painters in 14th and 15th centuries
- 19th Century eg. Romanticism, Realism, the Impressionists and Post-Impressionists
- 20th Century eg. Architecture and Design - Art Nouveau, Bauhaus - Expressionism, Surrealism, Pop Art

Key themes will also be studied. These can include:

- The human body in art - representations and symbolism
- Landscape in painting - Space and perspective in art
- Architecture and principles of construction
- Art and religion
- Women in art history
- What is art? Art and value (patronage, collectors, galleries, art market)

The course will also give the opportunity for practical engagement with art and architecture. For example:

- Copying or reinterpreting a masterpiece
- Construction of architectural models like a dome
- Design of objects (eg. chair, tea pot)

The opportunity to experience art will be important to the course including visits to art galleries and exhibitions

Assessment

The A mark in Art History can be based on the evaluation of the participation, of the workbook, of practical exercises and written homework.

The B mark is based on one B test per semester that includes also aspects of analysis of art works and one assessed semester project that can consist for instance of a presentation, a written analysis or a practical work

Contact

For further information, please contact

Mr David Watson (david.watson@teacher.eurisc.eu)

Ms Vasiliki Knitou (vasiliki.knitou@teacher.eurisc.eu)

ICT

Complementary course
2 periods per week

This course is open to all students, but it presupposes a strong basis, acquired in school or outside.

Objectives

This course is for students who wish to widen their knowledge and experience in the ICT field in preparation for their intended course of study or career. The objective of this course is therefore to provide a solid ICT background to pupils for whom information technologies will play an important role in both their professional and private lives. This course is intended for students who wish to expand their knowledge and experience in the field of ICT

Content

The course is based on the work done in previous years at school, but not only. Pupils improve their use of the Microsoft Office suite of programs and learn advanced aspects of computing such as object-oriented programming, 3D modeling, database, advanced web design and development, graphics, advanced word processing, advanced multimedia projects, and desktop publishing. The course extensively uses advanced techniques, such as the integrated Microsoft Visual Studio development environment and advanced web publications and graphic applications of the Adobe and Photoshop suite, as well as others.

In addition to the above-mentioned issues, projects in the field of 3d modeling and printing of designed objects on 3d printers will be implemented. There will also be an unmanned aircraft programming project/drone.

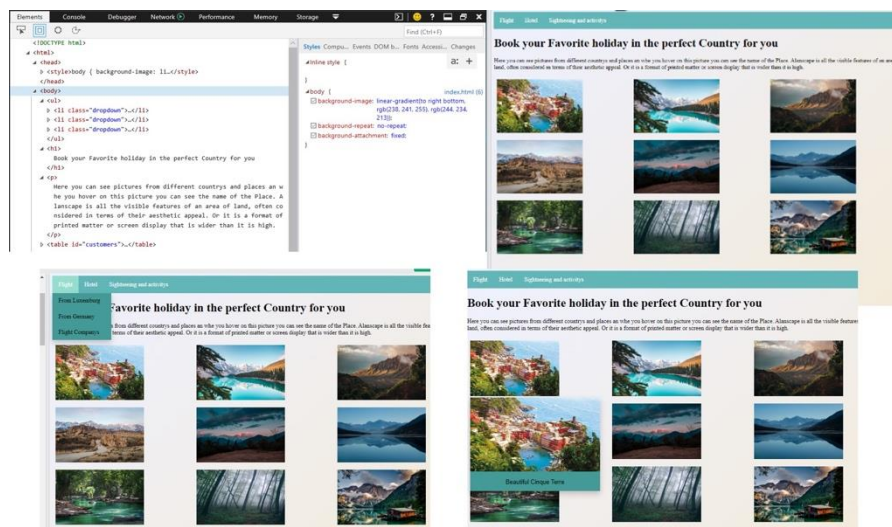

Assessment

Through one or two two-period tests each semester and/or by assessment of project work.

Contact

For further information, please contact your ICT teacher or the ICT coordinator, Mr Tomasz Prokop (tomasz.prokop@teacher.eursc).

INTRODUCTION TO ECONOMICS

Complementary course
2 periods per week

Objectives

- To have a general knowledge about the functioning of life in modern society.
- To give an introduction to the subject matter of economics to students who have not chosen it as a full option.
- To develop analytical skills in the formulation of arguments and the use of statistical data.
- To raise awareness of current economic issues.
- To develop the ability to express oneself using technical vocabulary.

Content

- A general introduction to economics and its principles.
- The circular flow of income.
- Money and the banking system.
- Markets and the determination of prices.
- The role of the state.
- Analysis of the basic economic problems of trade cycles, inflation, unemployment, and economic growth.
- International trade and exchange rates.

Assessment

6th/7th Years

One examination in class of one period at the end of each semester for the B mark. Continuous assessments for the A mark.

Contact

For further information, please contact the Economics coordinator, Mr Lars Thuesen (lars-naesgaard.thuesen@teacher.eurisc.eu).

L1A DEUTSCH L1, VERTIEFUNGSKURS

Wahlfach
wöchentliche Stunden: 3

Zielsetzung

Der Vertiefungskurs Deutsch umfasst drei Wochenstunden, die zusätzlich zum 4-stündigen Grundkurs erteilt werden. Ziel des Vertiefungskurses ist vor allem eine intensive Auseinandersetzung mit den Bereichen Literatur, Sprache und Medien, wobei über den deutschsprachigen Bereich hinaus auch der Vergleich mit Autoren anderer europäischer Literaturen angestrebt wird.

Der Vertiefungskurs wendet sich also in erster Linie an die Schülerinnen und Schüler, die ein besonderes Interesse an Literatur und Spaß am Lesen haben und sich mit grundlegenden sprachlichen Fragestellungen beschäftigen wollen. (Die Leistungen im Fach Deutsch sollten in der 5. Klasse mindestens befriedigend sein.)

Insbesondere solche Schüler, welche in Berufen mit hoher Sprachkompetenz arbeiten wollen (wie z.B. Manager, Juristen, Mediziner, Diplomaten etc.) werden hier ihre sprachlichen Fertigkeiten spürbar verbessern können. Die mündliche wie auch die schriftliche Präsentation von Resultaten sowie angeregte Diskussionen im Rahmen des Unterrichts werden an Intensität gewinnen können, weil es jedem Einzelnen wesentlich häufiger möglich sein wird, sich mit seinen Wortbeiträgen in das Unterrichtsgeschehen einzubringen. So werden die Schüler am Ende der Schullaufbahn über einen deutlich höheren aktiven Wortschatz in Deutsch verfügen können, in deren Folge sie ihre Eloquenz und Argumentationsfähigkeit entwickeln können.

Inhalt

Im Rahmen von zentral vorgegebenen Leitthemen, in deren Mittelpunkt eine Pflichtlektüre steht, werden literaturspezifische, aber auch gesellschaftliche und philosophische Zusammenhänge erarbeitet. Für das Abitur 2015 lautete dieses Pflichtthema beispielsweise „Irrwege der Phantasie“:

Basistext: E.T.A. Hoffmann: Der Sandmann

Verbindliche Begleitlektüre: Miguel de Cervantes: Don Quijote

Bewertung

Schriftliche Arbeiten:

Pro Halbjahr wird eine Klassenarbeit und eine Klausur ("Compo") geschrieben.

Abiturprüfung:

Schüler, die den Vertiefungskurs „Deutsch – Sprache I“ wählen, legen das Abitur im Fach Deutsch ausschließlich im Vertiefungskurs und nicht im Grundkurs ab.

In der 240 Minuten dauernden schriftlichen Prüfung wird die Analyse eines fiktionalen sowie eines nichtfiktionalen Textes verlangt.

Die mündliche Prüfung dauert 20 Minuten.

Kontakt

Weitere Informationen bei Herrn Alexander Mark (alexander.mark@teacher.eurasc.eu).

L1A ENGLISH L1 ADVANCED

Optional course

3 periods per week (2 periods if less than 5 students take the course)

The English L1 Advanced course provides students with a broader range of topics and opportunities for those interested in English language and, particularly, English literature.

Objectives

This course will enable you to:

- develop and embed the broad study of English (speaking and listening, reading, writing and the study of language)
- widen and deepen your knowledge and understanding of literature in English, including texts in translation where relevant;
- sharpen your analytical, creative and critical skills through opportunities for extended speaking and writing;
- pursue individual interests, e.g. in original writing; language acquisition and development; particular writers or genres; textual adaptation; or the impact of different media or technologies on audiences.

Content

Although there are components common to the L1 and L1A courses, L1A, allows for more diversity and a wider range of texts, and is thus **ideal preparation for those considering literary or linguistic studies in higher education.**

Set texts include a range of plays, novels and poetry from different social and historical contexts including Shakespeare and classic novels as well as more contemporary works and literary non-fiction.

A big part of the course is two substantial pieces of individual project work, chosen by the student, on a topic of their choice. One in S6 and one in S7.

Assessment

In S6:

- students will be given an A grade based on participation, contribution, in class and homework tasks and the individual project.
- The B grade will be the composition grade given in the December and June exams which will be based on the Baccalaureate exam.

S6 Individual Project

Students choose a topic which interests them and is agreed by the teacher. Some examples are: A language focused study; a media-based study; looking at how texts have been adapted; a literary study or authors or of genre; a collection of creative writing. The project should be between 2000 and 4000 words in length, depending on subject, content and complexity, and may consist of one long piece or several shorter, linked pieces as appropriate.

In S7:

- students will be given an A grade based on participation, contribution, in class and homework tasks and the individual project.
- The preliminary mark will consist of the A mark and the Pre-Bac mark which constitutes 50% of the overall grade.
- An oral exam (15%) and a written Baccalaureate exam (35%) in May / June

S7 Individual Project

An extended literary essay on a topic that involves the detailed study of several texts (e.g. a genre study; an author study; a thematic study; or a study of the impact of two or more contrasting text types in translation.) The essay should be around 5000 words in length and be agreed with the teacher.

S7 Written Examination

The written examination lasts for 240 minutes and comprises three compulsory questions:

Part 1 requires a critical commentary on a passage from the specified text studied in depth and to relate it both to the whole text and to associated works;

Part 2 requires you to choose one of two essays on the two sets of paired texts

Part 3 requires you to write a critical commentary on a previously unseen passage of non-fiction/non-literary prose, responding to content and style and the author's success in proposing an argument.

For the 2025 exam the texts are as follows:

Part 1 Set Text

Frankenstein by Mary Shelley, Wordsworth Classic ISBN 978-1853260230

Paired texts

The Poetry of Derek Walcott 1948 - 2013 edited by Glyn Maxwell, Faber and Faber ISBN 978-0571313815

The Speckled People by Hugo Hamilton, Fourth Estate ISBN 978-0007148110

and

King Lear, Oxford School Shakespeare ISBN 978-0198392224

Sylvia Plath Collected Poems ISBN 978-0571118380

Contact

For further information, please contact your L1 teacher or the English L1 coordinator Ms. Pamela Rigby (pamela-victoria.rigby@teacher.eursec.eu).

L1A FRANÇAIS LANGUE 1 APPROFONDISSEMENT

Cours à option
3 périodes par semaine

Le cours d'approfondissement est destiné aux élèves qui, à l'issue de la 5e année, manifestent un intérêt particulier pour l'étude du français, pour l'écriture, pour l'analyse et l'interprétation des textes littéraires ou, plus simplement, aux élèves qui ont envie de développer des compétences dans le domaine de la langue française et de la littérature francophone en vue d'étendre leur culture générale.

Les textes au programme (1 œuvre par an) sont envisagés en fonction d'une problématique littéraire.

Objectifs

- Développer des compétences en écriture (synthèse, reformulation, dissertation littéraire...)
- Parfaire les compétences de lecture et d'analyse des œuvres littéraires (et éventuellement de leurs adaptations théâtrales, cinématographiques...).
- Comparer des textes sur un thème commun, réfléchir et développer des points de vue argumentés sur des problématiques littéraires.
- Approfondir la connaissance de l'histoire littéraire et culturelle, et établir des rapprochements entre les genres littéraires, les époques, les arts, les cultures.
- S'engager dans un projet personnel créatif autour de la problématique de l'année (S6).

Contenu

en 6ème et 7ème années

Etude de deux thèmes illustrés par deux œuvres pivots et des œuvres complémentaires, qui font l'objet d'un programme renouvelé chaque année. Ainsi, pour l'année 2023-2024, voici les thèmes qui étaient proposés :

- en 6ème : L'artiste et ses désillusions : **Illusions perdues** de Balzac
- en 7ème : Le personnage romantique : **Hernani** de Victor Hugo
- Evaluation

en 6^e année :

- la note finale est basée sur la note A (participation orale, projet personnel et travaux écrits) et la note B (tests et résultat obtenu dans les compositions de fin de semestre).

en 7^e année :

- la note préliminaire résulte de la note A attribuée sur base de la participation orale et des travaux écrits et de la note B, résultat du Prébac.
- au Baccalauréat, l'élève présente une épreuve écrite (4 heures) et une épreuve orale (20 mn de préparation, 10 mn de présentation et 10 minutes d'entretien). Ces épreuves constituent le seul examen en langue I – en d'autres mots, les élèves qui ont choisi l'approfondissement comme option n'auront pas à passer en juin les épreuves de L1.

Contact

Pour de plus amples informations, veuillez contacter votre professeur de français L1 ou le coordinateur de français L1, Mme Catherine Bazin Mesnage (bazinmca@teacher.eursec.eu).

L1A PORTUGUÊS LÍNGUA 1 APROFUNDAMENTO

Optional course
3 períodos /semana

Objetivos

A disciplina de Aprofundamento de Língua I constitui-se como espaço de alargamento das aquisições da disciplina de Língua I. Assim, a disciplina de Aprofundamento destina-se a sedimentar e ampliar essa identidade num diálogo permanente com a LI. Por isso, o Aprofundamento de Português proporcionará a aprendizagem de uma linguagem literária e o desenvolvimento de uma sensibilidade estética mais profundos. Potencia uma maior intimidade com os textos, o que conduz à intensificação do prazer de ler e escrever no aluno mais motivado, possibilitando a consolidação do saber linguístico, e o descobrir da estética do texto ao aluno menos desperto ou com um domínio menos sólido da língua.

- Problematizar a natureza e o valor do texto literário como documento e monumento histórico-cultural e artístico:
 - estabelecer pontes entre a produção literária e outras expressões artísticas;
 - refletir criteriosamente sobre a produção estética e literária de língua portuguesa, a partir de obras representativas das diferentes épocas, períodos e correntes.
- Ler, interpretar e apreciar textos de caráter literário:
 - desenvolver a competência de leitura da dimensão simbólica do texto;
 - desenvolver técnicas de análise em literatura comparada.
- Desenvolver e aperfeiçoar a escrita sobre o texto:
 - a partir da produção textual, criativa e expressiva e a problematização dessa escrita pessoal enquanto investimento do desejo e da partilha que a criação pressupõe.

Conteúdo

As leituras literárias escolhidas construirão percursos significativos que facultem ao aluno, no final do 7.º ano, numa perspetiva diacrónica e sincrónica, uma visão panorâmica da Literatura Portuguesa.

TEMÁTICAS ORGANIZADORAS DAS LEITURAS

6.º Ano

- A escrita intimista e autobiográfica
- Imagens de Portugal na Literatura de Língua Portuguesa

7.º Ano

- A condição da mulher
- A Viagem

Avaliação

6.º Ano

- A nota final é o resultado da nota A (participação oral e trabalhos escritos) e da nota B (testes e resultado obtido nas composições de fim de semestre).

7.º Ano

A nota preliminar é o resultado da nota A (participação oral e trabalhos escritos) e da nota B (pré-BAC).

- No momento do Baccalaureat, o aluno realiza uma prova escrita (4 horas) e uma prova oral (20 min.). Estas provas constituem o único exame em Língua I.

Contacto

Para mais informação, contactar o professor de L1 ou o coordenador da disciplina, Prof. Abreu Poinha (maria-adelaide.abreu-poinha@teacher.eurisc.eu).

L2A DEUTSCH L2, VERTIEFUNGSKURS

Wahlfach
wöchentliche Stunden: 3

Zielsetzung

Ziel des Vertiefungskurses ist es, sich vor allem mit Hilfe von fiktionalen Texten ein möglichst differenziertes Bild der deutschsprachigen Länder zu erarbeiten. Historische und aktuelle Problemstellungen gilt es zu erkennen und zu beurteilen. Quer- und Längsschnitte durch verschiedene zeitgeschichtliche Epochen sollen helfen, ein umfangreiches Bild zu entwerfen und zu vertiefen. Die Schüler sollen in der Lage sein, selbständig Informationen über die deutschsprachigen Länder zu sammeln und zielgerecht auszuwerten.

Inhalt

Die inhaltlichen Schwerpunkte des Vertiefungskurses Deutsch L2 betreffen Themen vornehmlich aus Zeitabschnitten des 18. bis 20. Jahrhunderts; der Hauptakzent liegt hierbei auf der Beschäftigung mit der Literatur des 20. Jh. und 21. Jh.

Im Mittelpunkt des Unterrichts steht die Frage, was das Werk, der Autor und seine Zeit dem Schüler für Erkenntnisse über Deutschland, den angrenzenden deutschsprachigen Ländern und über seine Bewohner verschaffen können.

Die vier „klassischen“ Fertigkeiten des Sprachunterrichts: Leseverstehen, Schreiben, Hörverstehen **und Sprechen** werden in diesem Kurs integriert ausgebildet und vertieft. Die Texte für den Unterricht stammen aus allen drei literarischen Gattungen

Epik

Lyrik

Drama

Zur Vorbereitung des Abiturs müssen zwei Pflichtlektüren aus jeweils verschiedenen Gattungen behandelt werden, die rechtzeitig und verbindlich vom Fachlehrer zu benennen und in der 7. Jahrgangsstufe zu bearbeiten sind. Als Beispiel sei an dieser Stelle genannt:

Drama: Stella (J. W. von Goethe)

Epik: Katz und Maus (Günter Grass)

Auf diese Weise ist für alle Schüler, die den Vertiefungskurs gewählt haben, eine große Sicherheit gegeben, welche Lektüre im Abitur als Prüfungsgrundlage dient.

Bewertung

Schriftliche Arbeiten:

Pro Halbjahr wird im Vertiefungskurs eine Klassenarbeit und eine Klausur („Compo“) geschrieben.

Abiturprüfung:

Die schriftliche Abiturprüfung beinhaltet zwei Teile:

Teil 1: Leseverständnis

Teil 2: Textproduktion

Die Bearbeitungszeit in der schriftlichen Prüfung beträgt 240 Minuten.

Die mündliche Prüfung dauert 20 Minuten.

Kontakt

Weitere Informationen bei Frau Nadine Müntnich (nadine.muntnich@teacher.eurasc.eu).

L2A ENGLISH L2 ADVANCED

Optional course
3 periods per week

Students should have a good standard of written and spoken English. If a student has an average of above 8 for the 5th Year, he/she is certainly capable of doing this course. All students should show a genuine interest in Anglophone literature and cultural studies.

Objectives

- To develop skills in discussion and writing, regarding novels, plays and films. (It is **not**

primarily a language course, although inevitably pupils will learn a lot more English.)

- To develop listening and speaking skills to an advanced competency level.
- To instil a love of Anglophone literature and cultural studies.
- To prepare students for studying any kind of English course at University level or undertaking higher education in an English-speaking country. It will also be of great value to students intending to study subjects such as journalism, media, theatre, sociology, etc. or any subject where the analysis of texts written in English is a main component.

Content

Year 6

- A wide variety of texts are studied; short stories, novels, plays, poetry, and films, from GB, USA, Ireland, Australia, etc., focusing on Anglophone life and institutions.
- Materials are based on different themes and students may be asked to undertake personal research topics involving a wide range of study skills.
- Students will work either in small groups or individually to produce an extended research project on a literary theme of their choice, involving a presentational and a written aspect. The title of this work will be negotiated amongst the group.

Year 7

- For the BAC there is one set text, which is studied in depth.
- There is also one set theme which will require the study of a range of texts (from a written, pictorial or audio-visual source) covering the main areas of drama, prose fiction and non-fiction, and poetry.
- Students must also write a 2,000 – 3,000-word essay or make an extended oral presentation on a text of their choice. This will account for 50% of the second A mark.

Assessment

Year 6

- The A mark is based on oral contributions and written work set in class and for homework. The project in Year 6 is a significant part of this.
- The B mark is the result of tests and a written examination at the end of each semester.

Year 7

- A preliminary mark is given; this includes the A mark given each semester and one B mark.
- The B mark is the result of the partial examination (4 hours) in January.
- A final written paper (4 hours), and an oral examination if chosen, will be taken by pupils who have chosen the L2 Advanced option.

Contact

For further information, please contact your L2 teacher, or the L2-L3-L4 English coordinator, Ms Margarita Gudeikiene (margarita.gudeikiene@teacher.eursc.eu).

L2A FRANCAIS LANGUE 2 APPROF.

Cours à option
3 périodes par semaine

Ce cours est recommandé aux élèves, qui à l'issue de la cinquième année, ont acquis une maîtrise satisfaisante de la langue et manifestent un goût particulier pour l'étude du français et plus généralement pour les études littéraires et la lecture. Il est vivement conseillé de demander l'avis du professeur de français de 5e.

Objectifs

- développer les compétences de lecture, en diversifiant les supports : œuvres littéraires, images, adaptations cinématographiques...
- comparer des points de vue sur un thème commun.
- analyser un texte du point de vue de la syntaxe, du vocabulaire et du style.
- initier l'élève à l'histoire littéraire et aux civilisations des pays francophones.
- développer les compétences en expression orale au moyen d'exposés...

Contenu

en 6e et 7e années

- un programme renouvelé chaque année comporte deux thèmes illustrés chacun par une œuvre pivot, dont l'étude est obligatoire, et des œuvres complémentaires, dont l'étude est laissée à l'appréciation du professeur.

Ainsi, pour le Bac 2025, les deux thèmes choisis sont les suivants : "Littérature et documentaire" portant sur le roman d'Emmanuel Carrère, L'Adversaire et "Fiction fragmentaire et quête d'identité" : Histoire du fils de Marie-Hélène Lafon.

Évaluation

en 6e année :

- la note finale est basée sur la note A (notes d'oral et de travaux écrits) et la note B (résultats des tests et compositions de fin de semestre).

en 7e année :

- la note préliminaire résulte de la note A (travaux oraux et écrits) et de la note B (résultat du Prébac).
- au Bac, l'élève présente une épreuve écrite de 4 heures et une épreuve orale de 20 min. sur les textes au programme : ces épreuves constituent son seul examen de langue 2.

Contact

Pour de plus amples informations, veuillez contacter votre professeur de français, ou la coordinatrice de français L2-L3-L4, Mme Janka Rabcanova (janka.rabcanova@teacher.eursec.eu).

L3 DEUTSCH

Wahlfach
wöchentliche Stunden: 4

Zielsetzung

Ziel des Unterrichts im Fach Deutsch als Fremdsprache in der Sekundarstufe der Europäischen Schulen ist es, die Fähigkeiten der mündlichen und schriftlichen Kommunikation in der deutschen Sprache auszubauen. Im Deutschunterricht werden die vier Fertigkeiten Leseverstehen, Schreiben, Hörverstehen und Sprechen trainiert. Für die 2. Fremdsprache bedeutet dies in den Klassen 6 und 7:

Inhalt

LESEVERSTEHEN

Der Schüler soll die Technik des intensiven Lesens (inhaltliches und sprachliches Verständnis aller Einzelheiten) sowie des extensiven Lesens (Verständnis des Gedankengangs) erlernen. Dabei wird der Schüler arbeiten mit

- literarischen Texten verschiedener Gattungen (Kurzgeschichte, Erzählung, Roman etc.)
- Sachtexten zu bestimmten Themen
- Texten zur Landeskunde deutschsprachiger Länder.

SCHREIBEN

Der Schüler soll die Fähigkeit erwerben, ein Thema sprachlich angemessen wiederzugeben, zu beschreiben, zu kommentieren, zusammenzufassen oder zu interpretieren und sich in logisch-argumentativer Weise mit einer Problematik auseinanderzusetzen. Eine annähernd korrekte Rechtschreibung und die Beherrschung der grammatischen Grundstrukturen der deutschen Sprache werden erwartet, um differenziertere Strukturen bewältigen zu können.

HÖRVERSTEHEN

Unter Verwendung von authentischem Material wie beispielsweise einfachen Hörspielen, Nachrichten, Interviews, (Auszügen aus) Spielfilmen, Mitschnitten aus Fernsehprogrammen und Videos soll die Fähigkeit erweitert werden, Global- und Detailinformation wahrzunehmen, zu erfassen und zu interpretieren.

SPRECHEN

Der Schüler soll die Fähigkeit entwickeln, auf gehörte mündliche oder schriftliche Äußerungen in der Fremdsprache verständlich und geläufig in spontanem Dialog oder in zusammenhängender Rede zu reagieren.

Folgende Ganzschriften gehören beispielsweise zum Programm:

ABITUR 2023

Schuljahr 2021/22

Klasse 6: Wolfgang Herrndorf: Tschick

Schuljahr 2022/23

Klasse 7: Charlotte Kerner: Blueprint

Bewertung

Schriftliche Arbeiten:

Pro Halbjahr wird eine Klassenarbeit und eine Klausur ("Compo") geschrieben.

Abiturprüfung:

Der Schüler kann Deutsch als schriftliches oder mündliches Prüfungsfach im Abitur wählen.

Die Bearbeitungszeit in der schriftlichen Prüfung beträgt 180 Minuten.

Die mündliche Prüfung dauert 20 Minuten.

Die Eckpfeiler der Prüfung sind:

a) **schriftliches Abitur: 3 Teile**

Leseverständnis, Textproduktion, Literaturverständnis

b) **mündliches Abitur: 3 Teile**

Leseverständnis, Literaturverständnis, an Gesprächen teilnehmen.

Kontakt

Weitere Informationen bei Frau Nadine Müntnich (nadine.muntnich@teacher.eursc.eu).

L3 ENGLISH

Optional course
4 periods per week

Students taking this course will normally have studied English L3 from year 1 of the secondary school. The course is designed to build on the skills students have acquired during the past five years.

Objectives

- To develop skills in listening, speaking, reading and writing that allow students to use English for leisure, for future study and for their career.
- To develop communication skills in the areas of comprehension, interpretation and personal response.
- To explore a variety of different texts of a literary and non-literary nature.

Content

Year 6

- Improvement of language skills - listening, speaking, reading and writing.
- A variety of texts are studied, such as, the novel, play and film.
- Students are encouraged to read widely and to discuss a wide range of issues in English.
- Oral skills are developed– conversation, discussion, speeches, responses to fictional and non-fictional texts, oral summary, etc.

Year 7

- Students continue to build on the language skills obtained in Year 6 and previous years.
- Two set literary texts will be studied in detail for the Baccalaureate examination.

Assessment

Year 6

- The A mark is based on the oral contributions and written work set in class and for homework.
- The B mark is the result of a written examination at the end of each semester.

Year 7

A preliminary mark is given; this includes the A mark given each semester and one B mark. The B mark is the result of the partial examination (3 hours) in January.

Students may take either a final written examination (3 hours) or an oral examination.

The written examination consists of a reading comprehension exercise, 2 short essays and writing on one set literary text. For the oral examination, students should discuss an unprepared text, a picture and one of their set literature texts.

Contact

For further information, please contact your L3 English teacher, or the L2-L3-L4 English coordinator, Ms Margarita Gudeikiene (margarita.gudeikiene@teacher.eurasc.eu).

L3 ESPAÑOL LENGUA 3

Curso optativo
4 periodos semanales

Este curso exige un nivel correspondiente a cuatro años consecutivos de la enseñanza de esta lengua.

Objetivos

- Capacidad para comprender textos variados, orales y escritos en español contemporáneo **estándar**.
- Capacidad para expresarse oralmente y por escrito con fluidez y corrección sobre temas de interés general, y a partir de textos de cierta complejidad.
- Conocimiento de aspectos significativos de las culturas hispánicas (organización social, costumbres, **literatura española e hispanoamericana**).

Contenido

- Adquisición de la lengua en sus niveles fonéticos, morfosintáctico y léxico-semántico, especialmente en los aspectos que favorecen y enriquecen la comprensión y expresión.
- Desarrollo de las capacidades de comprensión y expresión oral y escrita y de interpretación de textos.
- Adquisición de conocimientos socioculturales y literarios.

Evaluación

en 6º curso:

Al final del curso, un examen escrito y un examen oral evaluarán las aptitudes para escuchar, leer, tomar parte en una conversación, expresarse oralmente sin interrupciones y escribir.

en 7º curso:

Para el examen de BAC el alumno puede elegir entre una prueba oral o una prueba escrita.

Prueba oral:

Las tres partes de la prueba oral evalúan:

- 1a parte: comprensión lectora. Un texto de 350 palabras (30 puntos)
- 2a parte: interacción oral sobre temas generales o de interés personal (40 puntos)
- 3a parte: comprensión de un texto literario sobre una de las dos obras leídas (30 puntos)

Tiempo de preparación de la prueba: 20 minutos

El alumno elige al azar un texto de entre una amplia gama de textos no literarios, que no ha estudiado en clase y lo prepara durante el tiempo señalado.

Duración de la prueba oral: 20 minutos

Los dos examinadores participan activamente en la prueba.

Prueba escrita:

La prueba escrita se compone de tres partes:

- 1ª parte: comprensión lectora (40 puntos)

- 2ª parte: producción escrita (30 puntos)
- 3ª parte: comprensión de un texto literario (30 puntos)

Duración del examen: 3 horas

- 1ª parte: comprensión lectora. 1-2 textos. 600 palabras en total.
- 2ª parte: producción escrita. Redacción de un texto de 300 palabras.
- 3ª parte: comprensión de un texto literario. Una tarea referida a uno de los dos libros obligatorios. Aproximadamente 300 palabras.

Contacto

Para más información, por favor contacte con su profesor de español o con la coordinadora de lengua española, la Sra. Domínguez (monica.dominguez-perez@teacher.eursc.eu).

L3 FRANÇAIS LANGUE 3

Cours à option
4 périodes par semaine

Objectifs

- consolider et enrichir les connaissances grammaticales et lexicales
- développer les capacités de compréhension écrite et orale.
- améliorer l'expression écrite et orale.
- initier l'élève à la lecture de textes francophones de littérature et de civilisation des XIX^e ; XX^e et XXI^e siècles.

Contenu

en 6e et 7e années

- révisions de grammaire et de syntaxe, en fonction des besoins et des lacunes constatées en classe, pour améliorer la qualité de la langue écrite.
- travail sur documents de nature diverse en langue contemporaine : articles de presse, œuvres complètes brèves, nouvelles, enregistrements sonores, films...
- initiation méthodologique aux exercices de compréhension et d'expression écrite du baccalauréat, d'étude d'un texte dans la perspective de l'épreuve orale.
- préparation à la prise de parole dans le cadre d'exposés ou de débats sur des sujets d'actualité.

Évaluation

en 6e année

- la note finale est basée sur la note A (oral et travaux écrits) et la note B (tests et compositions de fin de semestre).

en 7e année

- la note préliminaire résulte de la note A (oral et travaux écrits) et la note B (note du Prébac)
- au Baccalauréat, l'élève peut se présenter à une épreuve écrite de 3 heures ou à une épreuve orale de 20 min.
- l'épreuve écrite est un bilan des compétences de compréhension et d'expression écrites portant sur des textes non-littéraires (articles de presse, sondages, images, ...) ;
- une expression écrite (texte d'ordre pratique et texte de création) et une question sur l'œuvre étudiée en 6^{ème} ou en 7^{ème}.
- l'épreuve orale permet de vérifier la compréhension écrite de l'élève face à un texte nouveau non-littéraire pour lui, sa capacité à s'exprimer oralement, à faire des réflexions personnelles sur ce texte et à participer à une discussion en langue étrangère. Il y aura également une question portant sur l'œuvre étudiée en 6^{ème} ou en 7^{ème}.

Contact

Pour de plus amples informations, veuillez contacter votre professeur de français ou la coordinatrice de français L2-L3-L4, Mme Rabcanova (janka.rabcanova@teacher.eurisc.eu).

L3 ITALIANO

Opzione
4 Ore/Settimanali

Obiettivi

- Il corso si propone l'obiettivo di condurre gli allievi ad un'espressione corretta e disinvolta, sia orale che scritta, su argomenti di carattere generale.
- Questi ultimi vengono affrontati a partire dalla lettura di testi, di carattere prevalentemente non letterario, con lo scopo di sviluppare il senso critico degli alunni, permettendo loro di valutare e discutere le idee e i sentimenti espressi dallo scrittore.

Contenuti

Classe 6°

- Approfondimento dello studio delle strutture morfo-sintattiche acquisite, per ampliare il lessico;
- lettura e interpretazione di testi letterari e soprattutto di documenti contemporanei;
- esercizi di riassunto, schematizzazione e analisi di diversi tipi di testo;
- studio e sviluppo di uno o più temi particolari (cinema, arte, teatro, problemi sociali) attraverso letture, discussioni ed esposizioni scritte ed orali.
- Lettura di un'opera di narrativa contemporanea.

Classe 7°

- Sviluppo e approfondimento dei contenuti affrontati in 6°.
- Lettura di un'opera di narrativa contemporanea.

Valutazione

Si attribuisce un voto A sulla base dei compiti scritti eseguiti in classe e a casa, delle interrogazioni orali, della partecipazione e dell'interesse evidenziati in classe. Il voto B è il risultato dell'esame scritto di fine semestre in 6° (durata: 3 periodi) e della prova parziale di gennaio (durata: 3 ore) in 7°.

Ai fini dell'esame di baccalaureato gli allievi possono scegliere di svolgere l'esame scritto oppure l'esame orale.

Contatto

Per ulteriori informazioni, si prega di contattare il proprio insegnante di italiano o il coordinatore italiano, il sig. Zambito giovanni.zambito@teacher.eurisc.eu).

L4 DEUTSCH

Wahlfach
wöchentliche Stunden: 4

Zielsetzung

Ziel des Unterrichts im Fach Deutsch als Fremdsprache in der Sekundarstufe ist es, die Fähigkeiten der mündlichen und schriftlichen Kommunikation in der deutschen Sprache auszubauen. Im Deutschunterricht werden die vier Fertigkeiten Leseverstehen, Schreiben, Hörverstehen, und Sprechen trainiert. Für die 3. Fremdsprache bedeutet dies in den Klassen 6 und 7:

Inhalt

LESEVERSTEHEN

Im Unterricht der 3. Fremdsprache steht die Erweiterung und Vertiefung der Lesefähigkeit im Vordergrund. Durch einfache Fragen soll das Globalverständnis überprüft werden. Um bei Texten Zeit für die gemeinsame Lektüre wesentlicher Textstellen zu gewinnen, kommt es darauf an, die Technik des kursorischen Lesens (Zusammenfassung weniger wichtiger Abschnitte oder Kapitel) zu erlernen. Gearbeitet wird teilweise mit

- Lehrbuchtexten
- Sachtexten
- einfacheren literarischen Texten

SCHREIBEN

Der Schüler soll die Fähigkeit erwerben, ein Thema sprachlich in zusammenhängender Weise wiederzugeben, zu beschreiben, zu kommentieren oder zusammenzufassen. Ein sicheres Beherrschen der grundlegenden grammatischen Strukturen der deutschen Sprache ist Ziel des Unterrichts.

HÖRVERSTEHEN

Unter Verwendung von authentischem Material wie beispielsweise einfachen Hörspielen, Nachrichten, (Auszügen aus) Spielfilmen, Mitschnitten aus Fernsehprogrammen und Videos, soll die Fähigkeit erworben werden, Global- und Detailinformation wahrzunehmen.

SPRECHEN

Der Schüler soll die Fähigkeit entwickeln, auf gehörte mündliche oder schriftliche Äußerungen angemessen in der Fremdsprache zu reagieren.

Bewertung

Schriftliche Arbeiten:

Pro Halbjahr wird eine Klassenarbeit und eine Klausur ("Compo") geschrieben.

Abiturprüfung:

Der Schüler kann Deutsch als schriftliches oder mündliches Prüfungsfach im Abitur wählen.

Die Bearbeitungszeit in der schriftlichen Prüfung beträgt 180 Minuten.

Die mündliche Prüfung dauert 20 Minuten.

Die Eckpfeiler der Prüfung sind:

a) **schriftliches Abitur: 2 Teile:**

Teil 1: Leseverständnis (60%)

Teil 2: Textproduktion (40%)

b) **mündliches Abitur:**

Teil 1: Leseverständnis

Teil 2: zusammenhängend sprechen und an Gesprächen teilnehmen

Der Schüler kann Deutsch als schriftliches oder mündliches Prüfungsfach im Abitur wählen.

Kontakt

Weitere Informationen bei Frau Nadine Müntnich (nadine.muntnich@teacher.eurasc.eu).

L4 ENGLISH

Optional course
4 periods per week

Students taking this course will normally have studied English L4 from year 4 of the secondary school.

Objectives

- This course is designed for students who wish to study English for the purposes of leisure, studying or for career.
- To develop communication skills in the areas of comprehension, interpretation and personal response.
- Specific attention will be given to improving students' skills in listening, speaking, reading and writing.
- To develop the skills through the study of themes and texts chosen to suit the level.

Content

Year 6

- A variety of texts, both literary and non-literary will be studied to allow students to extend the skills they have acquired in previous years, e.g. short stories, novels, drama, poetry, films, etc.

Year 7

- Continued study of a wide variety of texts.
- Development of writing skills enabling students to respond to the text on the level of personal evaluation or creative text production.
- Listening and speaking skills are continuously developed, building on skills acquired in previous years.

Assessment

Year 6

- The A mark is based on oral contributions and written work set in class and for homework.
- The B mark is the result of a written examination at the end of each semester.

Year 7

- A preliminary mark is given; this includes the A mark given each semester and one B mark. The B mark is the result of the partial examination (3 hours) in January.
- Students may take either a final written examination (3 hours) or an oral examination.

Contact

For further information, please contact your L4 teacher or the L2-L3-L4 English coordinator, Ms Margarita Gudeikiene (margarita.gudeikiene@teacher.eurasc.eu).

L4 ESPAÑOL LENGUA 4

Curso optativo
4 periodos semanales

Este curso exige un nivel correspondiente a dos años consecutivos de la enseñanza de esta lengua.

Objetivos

Capacidad para comprender textos escritos y documentos orales en español contemporáneo **estándar**.

Capacidad para expresarse oralmente y por escrito, con relativa facilidad, sobre temas de interés general y a partir de textos de dificultad media.

Adquisición de conocimientos sobre aspectos significativos de la cultura hispánica.

Contenido

Lingüístico : Mejorar y enriquecer la gramática, la fonética y el vocabulario.

Cultural : Conocimiento de las tradiciones, costumbres, modos de vida, etc.

Literario : Lectura de una obra por año adaptada al nivel de conocimientos adquiridos.

Evaluación

en 6º curso:

La nota final es el resultado de la nota A (participación en clase, deberes, exámenes...) y la nota B (resultado de los exámenes y composiciones de fin de semestre).

en 7º curso:

La nota preliminar es el resultado de la nota A (participación en clase, deberes, exámenes...) y la nota B (resultado de la prueba parcial de enero).

Para el examen de BAC el alumno puede elegir entre una prueba oral o una prueba escrita.

Prueba oral:

El alumno saca por sorteo un texto con dos o tres cuestiones. Dispone de 20 minutos para exponer su interpretación del texto y entablar un diálogo con los examinadores.

Prueba escrita:

Estructura de la propuesta y tipología de las preguntas.

El examen constará de dos partes:

1ª Parte-Comprensión

Consta de dos textos (uno literario y otro no literario) y de ocho a doce preguntas de comprensión. Las preguntas son de respuesta cerrada. (60% de la nota).

2ª Parte-Redacción

El objetivo es que el alumno **elija dos** de las **tres opciones** propuestas utilizando unas 200 palabras para cada una de ellas.

Contacto

Para más información, por favor contacte con su profesor de español o con la coordinadora de lengua española, la Sra. Domínguez (monica.dominguez-perez@teacher.eursc.eu).

L4 FRANÇAIS LANGUE 4

Cours à option
4 périodes par semaine

Objectifs

Le travail en 6e et 7e consistera surtout à approfondir et élargir les acquis des deux années précédentes, à savoir :

- entraînement à l'expression orale,
- développement des capacités de compréhension écrite et orale,
- amélioration et développement de l'expression écrite,
- enrichissement du vocabulaire, fixation des structures syntaxiques et amélioration de l'orthographe grammaticale.

Contenu

- étude de la langue : travail visant à enrichir le vocabulaire, à améliorer la syntaxe et l'orthographe grammaticale.
- travail sur des documents de nature diverse, adaptés à la réalité de la classe, en langue contemporaine : méthodes de français langue étrangère, articles de presse, œuvres complètes brèves, si c'est possible, enregistrements sonores, films, etc.
- préparation à la prise de parole dans le cadre d'interviews, d'exposés, de débats...
- divers exercices d'entraînement à l'expression écrite : lettres, réponses à des questions de compréhension sur un texte, petits textes narratifs et argumentatifs...

Évaluation

en 6e année :

- la note finale est basée sur la note A (oral et travaux écrits) et la note B (tests et compositions de fin de semestre).

en 7e année :

- la note préliminaire résulte de la note A (oral et travaux écrits) et de la note B (note du Prébac).
- au Baccalauréat, l'élève peut se présenter à une épreuve écrite de 3 heures ou à une épreuve orale de 20 min.
- l'épreuve écrite comporte des questions de compréhension portant sur deux textes inconnus de l'élève et deux exercices d'expression écrite qui permettent à l'élève d'exprimer son point de vue sur un sujet donné ou d'écrire un texte narratif...
- l'épreuve orale porte sur un texte inconnu de même nature que ceux étudiés en classe et permet à l'élève d'exposer les idées contenues dans le texte et d'avoir une conversation en langue étrangère avec les examinateurs

Contact

Pour de plus amples informations, veuillez contacter votre professeur de français ou la coordinatrice de français L2-L3-L4, Mme Rabcanova (janka.rabcanova@teacher.eursec.eu).

L4 ITALIANO

Opzione
4 Ore/Settimanali

Obiettivi

- Condurre gli allievi a un'espressione scritta ed orale, corretta ed efficace, e sviluppare la loro capacità di comprensione ed interpretazione.

Contenuti

Classi 6° e 7°:

- Ripresa e consolidamento delle strutture morfo-sintattiche acquisite in 4° e in 5°;
- estensione del lessico (sinonimi, campi semantici....);
- lettura ed analisi di alcune pagine di narrativa contemporanea e di documenti contemporanei;
- riassunti, schematizzazioni, commenti, composizioni in riferimento a uno o più argomenti di attualità e di cultura generale;

Valutazione

Si attribuisce un voto A sulla base dei compiti scritti svolti in classe e a casa, delle interrogazioni orali, della partecipazione e dell'interesse evidenziati in classe. Il voto B è il risultato dell'esame scritto di fine semestre (durata: 3 periodi) in 6° e della prova parziale di gennaio in 7° (durata: 3 ore). Ai fini dell'esame di baccalaureato gli allievi possono scegliere di svolgere l'esame scritto oppure l'esame orale.

Contatto

Per ulteriori informazioni, si prega di contattare il proprio insegnante di italiano o il coordinatore italiano, il sig. Giovanni Zambito (giovanni.zambito@teacher.eurisc.eu).

L4 PORTUGAIS LANGUE 4

Cours à option
4 périodes par semaine

Objectifs

Le travail en 6e et 7e consistera surtout à approfondir et élargir les acquis des deux années précédentes:

1. Comprendre les points principaux des messages liés à des domaines d'intérêt personnel, et pertinence et avec des sujets d'intérêt général.
2. Lire et comprendre les points essentiels de textes littéraires et non littéraires liés aux domaines d'intérêt personnel et des sujets d'intérêt général.
3. Interagir dans des situations courantes et simples et participer à une conversation sur des sujets variés qui sont familiers, d'intérêt personnel ou pertinents pour la vie quotidienne.
4. Écrire des textes courts, simples et cohérents sur des sujets familiers et des sujets d'intérêt personnel.
5. Relier les connaissances culturelles acquises à des pays d'expression portugaise.

Contenu

1. Étude de la langue : des règles de prononciation, d'intonation et d'orthographe, de vocabulaire et d'expressions, morphologie et de structures grammaticales ;
2. Analyse de documents authentiques (publicité, article de la presse...)
3. Développement de la compréhension et expression orale ;
4. Développement de l'expression écrite : rédaction de textes de différentes typologies.
5. Approfondir la connaissance de la culture des pays lusophones.

Évaluation

en 6e année :

- la note finale est basée sur la note A (oral et travaux écrits) et la note B (tests et compositions de fin de semestre).

en 7e année :

- la note préliminaire résulte de la note A (oral et travaux écrits) et de la note B (note du Prébac).
- au Baccalauréat, l'élève peut se présenter à une épreuve écrite ou à une épreuve orale.
- l'épreuve écrite (de 3 heures) comporte des questions de compréhension et deux exercices d'expression écrite qui permettent à l'élève d'exprimer son point de vue sur un sujet donné ou d'écrire un texte narratif.
- l'épreuve orale (de 20 min.) porte sur un texte inconnu de même nature que ceux étudiés en classe et permet à l'élève d'exposer les idées contenues dans le texte et d'avoir une conversation en langue étrangère avec les examinateurs.

Contact

Pour de plus amples informations, veuillez contacter votre professeur de portugais ou la coordinatrice de la matière, Mme Abreu Poinha (maria-adelaide.abreu-poinha@teacher.eurisc.eu).

L5 CHINESE

Complementary course
2 periods per week

Objectives

你好。我学习汉语。

Chinese is not an easy language, but today China is such a dominant global player that notions of the language are an important asset for whatever you decide to study or do afterwards. All S6-S7 students are welcome, but especially those who are eager to broaden their horizons and who have a passion for language will be satisfied. Here are some of the objectives:

- Building a basic vocabulary around certain themes such as getting to know each other, asking directions, presenting oneself and more.
- To learn to write and read a package of about 200 basic Chinese characters, in order to recognise a basis of characters in the Chinese streets.
- An introduction to the uniqueness of Chinese culture and society.

Content

This course offers an introduction to the language and the country, with its rich cultural and historical heritage. The focus in the lessons is on dialogue and culture.

We use *pinyin*, a transcription system which enables us to read Chinese without necessarily knowing all the characters. On a regular base and with some digital tools, we will also learn to write a selection of important characters. Now and then there is a lesson on Chinese history or culture, so that we also get to understand nowadays China.

Assessment

Evaluation is by formative assessment and by participation and work in class.

Contact

For further information, please contact Mr Nikolaas de Rijcke (nikolaas.de-rijcke@teacher.eursc.eu).

L5 DUTCH

Complementary course
2 periods per week

Objectives

The main objectives of this course are the following:

- understand written and oral conversations in Dutch and understand the main point in short, clear, simple messages and announcements;
- communicate in simple and everyday language about familiar and everyday issues (family, friends, hobbies, weekly activities...);
- write in simple words about their own background, current environment, various wishes and needs
- get to know the Dutch and Flemish culture through videos, songs, articles...

Content

Vocabulary fields:

- Family and friends
- Hobbies and daily/weekly activities
- Time/planning
- Weather
- Living
- Clothes
- (Grocery) shopping
- Feelings
- Illness
- Public transport
- ...

Grammar:

- Structure of Dutch sentences
- Tenses (present, past, future)
- Adjectives
- Comparatives and superlatives
- Plural forms
- Negation
- ...

Pronunciation

Dutch culture

Assessment

The pupils will be assessed through written texts, oral presentations/dialogues, mini tests and long tests. There are no exams (compos/Bac) in L5.

Contact

For further information, please contact the Dutch language teacher Ms Anne Van Severen (vansevan@teacher.eursc.eu).

L5 ITALIAN

Complementary course
2 periods per week

(To be published soon)

Objectives

Content

Assessment

Contact

For further information, please contact the Italian coordinator, Mr Zambito (giovanni.zambito@teacher.eursec.eu).

L5 LËTZEBUERGESH

Complementary course
2 periods per week

Objectives

By the end of S7, the student should be able to:

1. understand familiar words and everyday expressions relating to himself/herself, his/her family and his/her environment, if people speak slowly and distinctly
2. read and understand short, simple texts of an everyday nature
3. interact in a simple way, and ask and answer simple questions in areas of practical need or on very familiar topics
4. use simple phrases and sentences to describe persons and things familiar to him/her
5. write short simple texts on familiar topics and fill in forms
6. demonstrate basic understanding of some aspects of the culture of the target language countries/communities
7. relate elements of his/her existing cultural awareness to elements of the culture of the target countries/communities
8. identify and apply basic strategies for learning languages
9. apply basic study skills and tools to the learning of the target language

Content

By the end of S7, the student should have acquired:

- basic knowledge of pronunciation, intonation and spelling rules
- knowledge of basic vocabulary and expressions
- knowledge of basic morphology and basic grammatical structures
- knowledge of how to use dictionaries and other resources, including digital ones
- an awareness of some aspects of the culture of the Luxembourgish language
- an awareness of language learning strategies including an awareness of their own progress

Assessment

The Luxembourgish language is not assessed at the Baccalaureate. The mark given for the European Baccalaureate is based on:

- a) formative assessment in the classroom (B-mark: 2 long tests per term each of 45 minutes in years 6 and 7)
- b) class-based tests in listening, reading, spoken interaction, spoken production and writing. (A-mark)

Contact

For further information, please contact the Luxembourgish language teacher, Ms Karen (marianne.karen@teacher.eurisc.eu).

L5 MODERN GREEK Νέα Ελληνικά

Complementary course
2 periods per week

All students can take this course

Objectives

By the end of S 7, the student should be able to:

1. understand familiar words and everyday expressions relating to himself/herself, his/her family and his/her environment, if people speak slowly and distinctly
2. read and understand short, simple texts of an everyday nature
3. interact in a simple way, and ask and answer simple questions in areas of practical need or on very familiar topics
4. use simple phrases and sentences to describe persons and things familiar to him/her
5. write short simple texts on familiar topics and fill in forms
6. demonstrate basic understanding of some aspects of the culture of the target language countries/communities
7. relate elements of his/her existing cultural awareness to elements of the culture of the target countries/communities identify and apply basic strategies for learning languages
8. apply basic study skills and tools to the learning of the target language

Content

By the end of S 7, the student should have acquired:

- basic knowledge of pronunciation, intonation and spelling rules
- knowledge of basic vocabulary and expressions
- knowledge of basic morphology and basic grammatical structures
- knowledge of how to use dictionaries and other resources, including digital ones
- an awareness of some aspects of the culture of the target language countries/communities
- an awareness of language learning strategies including an awareness of their own progress

Assessment

The assessment should be mainly formative.

The mark given for the European Baccalaureate is based on:

- a) formative assessment in the classroom and
- b) class-based tests in listening, reading, spoken interaction, spoken production and writing

Contact

For further information, please contact Ms Vasiliki Knitou (knitouva@teacher.eursec.eu).

L5 PORTUGUESE

Complementary course
2 periods per week

(To be published soon)

Objectives

Content

Assessment

Contact

For further information, please contact the Portuguese coordinator, Ms Abreu Poinha (maria-adelaide.abreu-poinha@teacher.eursec.eu).

L5 SPANISH

Complementary course
2 periods per week

Objectives

To understand and to produce written and oral simple texts in standard Spanish, especially those related to personal information and basic areas of communication: restaurants, shops, free time activities...

To gain the interest and some basic knowledge about Spanish culture.

Content

Linguistic: basic grammar rules, phonetics and vocabulary.

Cultural: general information about Spain and Spanish speaking countries, traditions, etc.

Assessment

Note A includes participation in class, homework, etc. Note B is for tests results.

Contact

For further information, please contact Ms. Domínguez (monica.dominguez-perez@teacher.eursc.eu).

LABORATORY BIOLOGY

Complementary course
2 periods per week

Objectives

The laboratory classes aim to develop practical techniques, develop critical sense, ability to work in group, development and application of the scientific method.

Content

The teacher is free to choose the experiments in relation to the subject matter of the optional course and the materials available.

Assessment

There is no examination at the baccalaureate. A mark is the result of class assessment and B mark is the result of the arithmetic average of 2 long reports.

Contact

For further information, please contact your Biology teacher.

LABORATORY CHEMISTRY

Complementary course
2 periods per week

This course is designed for students interested in an in depth study of chemistry through **experimental work**. Students wishing to study chemistry, biochemistry, medicine, veterinary science at University are strongly advised to take this course. For students wishing to study any engineering or science course, it is highly recommended to take a complementary practical course.

Objectives

- Deepen and consolidate knowledge of chemistry with experiments that complement the theory classes of the 4 period option course.
- Strengthen manual skills for the handling of chemicals and apparatus
- Develop powers of observation and the ability to write laboratory reports
- Teach students the scientific method

Content

The teacher is **free** to choose experiments of organic and inorganic chemistry in relation to the subject matter of the course in years 6 and 7.

Assessment

The class mark is based on experimental work and written reports of the experiments. There is no examination at the baccalaureate. There is one test each semester.

Contact

For further information, please contact your Chemistry teacher.

LABORATORY PHYSICS

Complementary course
2 periods per week

Objectives

The aim of this course is to familiarise pupils with the experimental techniques and practices, which are at the heart of physics. This course is very useful for students who intend to pursue further studies in physics or in a related discipline, for it allows them to complete their approach to physics.

Content

Techniques of measurement in the different areas of physics are introduced during the two years. The accent is placed on the problems of how to take measurements, and how to treat data and errors arising from measurements.

Pupils are provided with modern equipment, which permits them amongst other things to utilise modern methods for the collection and analysis of experimental data. They will use different computer programs or their calculators to analyse data.

Assessment

Formal long written tests should not be used for the assessment of students. The assessment can be based on the student's level of participation, the reports prepared by the student, their projects, presentations and communication skills.

A mark: It will be based on observation of students during practical activities, the written reports quality, the ability to make oral and/or written presentation skills.

B mark: For each semester a B mark will be given. It will be based on a simple experience carried out by the students with the elaboration of a short-written report (two class periods)

Contact

For further information, please contact your Physics teacher

LATIN

Optional course
4 periods per week

LEGITE TEXTUS ORIGINALES – FUNDAMENTA EUROPÆ!

The study of Latin in the 6th and the 7th years is a natural follow on from the work done during the previous four years. The course in 6th and 7th is taught in the student's mother tongue if 5 qualified candidates take this option. If not, the students will study the subject in their vehicular language or, if possible, in mixed language groups, in which the students use their mother tongue and the teacher teaches in two or three languages.

Objectives

By the end of S7, pupils should be able to

- read, understand and analyse literary and non-literary texts
- Show in-depth knowledge of the ancient world (in a scientific, legal, philosophical, literary or economic context)
- To present the ancient heritage in its various dimensions in a precise and differentiated way
- to use classical culture for the understanding of contemporary culture
- To deepen the relationship between Latin and other living languages
- To critically examine the accessible resources
- to see Latin as a springboard for personal and professional future

Content

For each of the years S6 and S7 there is a central theme that needs to be addressed.

At present, for example, it is "Rome and Africa" -. This is about the expansion of the Roman Empire in northern Africa, the importance of the African provinces, the exchange of different cultures, but also about the enmity between Rome and Carthage. The planned theme for S6 (starting autumn 2024) is "Homo et animal".

This topic will be dealt with by reading a wide range of original texts and then discussed in a historical context or compared to our present situation. The students are thus immersed in Roman culture, literature, archaeology and philosophy.

In this way, the students not only learn a lot about antiquity, but also about the present and thus about themselves.

Ancient literature can be recognised as the basis of our European civilisation and as a source for understanding world literature.

Assessment

Students are assessed on the basis of their oral participation in the lessons, presentations on the topic and written examinations such as long tests.

In addition, at the end of the S7, they acquire the certificate "LATINUM EUROPÆUM SUPERIUS" if they successfully complete the Latin course.

For the Baccalaureate examination a student may choose Latin as one of her/his written examinations: a translation of an unseen text, using a dictionary, questions on seen texts studied during the year and writing an essay about this topic.

In any case, the student takes Latin as a full-length examination ("Prébac") based on the theme studied in class at the end of the first term of the 7th year.

Contact

For further information, please contact your Latin teacher, or the Latin coordinator, Ms Scheicher (nadja.scheicher@teacher.eurisc.eu).

MATHEMATICS

In years 6 and 7, Mathematics can be studied at 3 levels:

- Elementary Course (3 periods/week)
- Standard Course (5 periods/week)
- Advanced Course (3 periods/week in addition of the standard course)

Students must follow either the Elementary or the Standard course.

The advanced course is optional. Only students following the Standard Course may choose to follow the Advanced Course.

All students must be in possession of a graphing but **non-CAS** calculator with the following specifications:

Required functionalities:

- Trigonometric functions
- Exponential & logarithm
- Numerical equation(s) solving
- 1-Var & 2-Var Statistics
- Factorials & combinations
- Binomial distribution
- Normal distribution
- Functions: Table of values
- Numeric integration
- Numerical differentiation
- Graphing

MATHEMATICS 3

Compulsory Course
3 periods per week

Objectives

This course is designed for students who will not study subjects in the future which may require an extensive knowledge of mathematics. It aims to help students to better understand the scientific and technical world around them while avoiding developing theoretical ideas. The course logically follows on from the 4-period course studied in the 4th and 5th years.

Content

- Analysis – problem solving, functions and basic calculus
- Statistics
- Probability

Assessment

This course leads to a compulsory 4-hour written examination. Two hours of this exam will test the acquired knowledge and skills of this course without the aid of any technological tool. The remaining two hours will be completed using the calculator.

Contact

For further information, please contact your Mathematics teacher.

MATHEMATICS 5

Compulsory course
5 periods per week

Students must be familiar with those parts of the 5th year 6-period syllabus, which are necessary in order to follow the 5-period course.

Objectives

This course is designed for students who will benefit from having a solid mathematical foundation and who are likely to continue in Further Education to study Mathematics or subjects requiring an extensive knowledge of Mathematics (e.g. Engineering, Physics, Physical Sciences, ...). The course is a logical continuation of the 6-period course of the 4th and 5th years.

Content

- Analyses: sequences, functions and calculus
- Complex numbers
- Geometry in 2 and 3-dimensional space
- Probability
- Statistics

Assessment

This course leads to a compulsory 4-hour written examination. Two hours of this exam will test the acquired knowledge and skills of this course without the aid of **any** technological tool. The remaining two hours will be completed using the calculator.

Contact

For further information, please contact your Mathematics teacher.

ADVANCED MATHEMATICS

Optional course
3 periods per week

Objectives

This course is designed for those students at ease with the subject and who are likely to study Mathematics or subjects requiring a high level of Mathematics (e.g. Physics, engineering,) at university or in further Education. The students will confront ideas and problems requiring insight and understanding.

Content

In the 6th Year

Compulsory parts:

- Foundations of Mathematics (sets theory, Vocabulary reasoning and proof, relations and functions)
- Arithmetic (congruencies, prime numbers)
- linear algebra (vector spaces, basic concepts of matrices, systems of equations)
- analysis classical theorems

In the 7th Year

Compulsory part:

- Linear Algebra (vector spaces and linear transformations, determinants, inverse of a matrix, systems of equations)
- Analysis (Taylor and Mc Laurin formulae, integration techniques, differential equations)

Optional part:

2 topics chosen from a list of 28. These topics are chosen according to the interests and requests of the pupils in the class.

Assessment

Baccalaureate

This course leads to a compulsory oral examination.

Such an examination will test the knowledge, understanding and mathematical maturity of the student. The ability to present a valid mathematical argument and show insight on a topic will be measured.

Contact

For further information, please contact your Mathematics teacher.

MUSIC 2

Complementary course
2 periods per week

This course is open to all students, from a variety of musical backgrounds (school, private, conservatoire; pop/rock and classical) who are enthusiastic about music and are able to read and write music to some extent.

Objectives

The main objectives are to develop:

- a knowledge and understanding of musical styles, genres and traditions
- an appropriate and relevant knowledge and understanding of music theory
- aural awareness, analytical and score reading skills
- performing and composing skills
- an ability to apply musical knowledge in a critical and discerning way

Content

In years 6 and 7

- An outline of the musical styles and their characteristics
- An outline of 20th/21st century musical styles and their characteristics (including pop/rock/jazz)
- Score reading and analysis, identification of compositional techniques, technical aspects of score-reading.
- Performing music
- Composing music (using music technology and other means)
- Creating a portfolio containing compositions, performances, analyses, and other elements reflecting the musical development of the student

Assessment

Year 6 and 7:

- oral contribution, practical work in class (composing, performing) and written tests
- portfolio (documentation of compositions, performances, critical reviews, etc.)

Contact

For further information, please contact your Music teacher or the Music coordinator, Mrs Britta Schwarte (schwarbr@teacher.eurasc.eu).

MUSIC 4

Optional course
4 periods per week

This course is open to all students, from a variety of musical backgrounds (school, private, conservatoire; pop/rock and classical) who are enthusiastic about music. They should be able to read and write music and to perform to a reasonable level on an instrument or using their voice.

Objectives

The main objectives are to develop:

- a knowledge and understanding of musical styles, genres and traditions. This includes the development of Western classical music from medieval times to the present day, as well as having a wide appreciation of pop/rock/jazz and non-Western musical traditions.
- an appropriate and relevant knowledge and an understanding of music theory
- aural awareness, analytical and score reading skills
- performing and composing skills
- an ability to apply musical knowledge in a critical and discerning way

Content

In years 6 and 7

- An outline of the styles and their characteristics in the history of Western classical music (*medieval, renaissance, baroque, classical, romantic*)
- An outline of 20th/21st century musical styles and their characteristics (including pop/rock/jazz)
- Score reading and analysis, identification of compositional techniques, technical aspects of score-reading.
- Analysis of four set topics of different origins (details, such as special composers, styles or countries change yearly)
 1. Western art music in the 20th and 21st century
 2. Musical theatre and/or Jazz
 3. 21st century popular music
 4. Non-western music
- Performing music
- Composing music (using music technology and other means)
- Creating a comprehensive portfolio containing compositions, performances, analyses, and other elements reflecting the musical development of the student

Assessment

BAC Examination

Pre-BAC (40% of overall mark)

performing and composing (30% or 40% of Pre-Bac mark according to personal choice)

Research Project (30% of Pre-Bac mark)

BAC (60% of overall mark)

Written listening and responding examination (50% of Bac mark): identifying styles, score reading and questions concerning the four set topics

Portfolio (50% of Bac mark): documentation, compositions, performances, critical reviews, etc.

Contact

For further information, please contact your Music teacher or the Music coordinator, Mrs Britta Schwarte (schwarbr@teacher.eurisc.eu).

PHILOSOPHY

The 4-period philosophy is not more difficult, but more profound. The two-period philosophy is more superficial and you don't have time to develop every aspect in detail.

In both courses, but especially in Ph4, you read and discuss original texts written by famous philosophers. A good knowledge of L1 is an advantage, especially in Ph4. The same applies in the other direction as well - philosophy often helps students to become better at L1.

The skills required are mastery of the language, logic, academic knowledge provided in class and learning how to write.

Philosophy has clear benefits for many future studies – anywhere where people care about critical engagement with the truth and questions of proof. It is as relevant, therefore, to future scientists and mathematicians as it is to future lawyers and politicians.

PHILOSOPHY 2

Compulsory course⁴
2 periods per week

Objectives

In the course of class study in these domains, the pupils will get to know the theories of several philosophers, from Antiquity, from the 16th-18th centuries and contemporary philosophers.

But it is not a question of learning theories or dates by heart...the idea is to better our understanding of ourselves and the world. And additionally, to learn to express ourselves effectively so that others can understand us.

Content

We learn to ask ourselves questions in four particular domains:

- Epistemology
 - Theory of knowledge
 - Theory of science
- Ethics
- Political philosophy
 - The state of nature and the social state
 - Democracy
 - Ideologies
- Anthropology
 - Existentialism
 - Essentialism

Assessment

The Baccalaureate exams

Students can only choose to take an oral examination:

The oral exam - The pupil picks a random question, which will be a text followed by sub-questions. The pupil has 20 minutes to study/analyse it and to prepare answers to the questions. The oral exam, in which the pupil presents his results in form of an exposé and answers questions also lasts 20 minutes.

⁴ This course is compulsory unless Philosophy is chosen as 4-period option.

Contact

For further information, please contact the Philosophy coordinator, Dr Peter Duncombe (peter.duncombe@teacher.eurisc.eu).

PHILOSOPHY 4

Optional course
4 periods per week

Every student, whether a specialist in science or literature, can enrol on this course... and do well in it.

Nevertheless, some conditions apply:

- Good level in the language of the course as texts need to be understood and ideas expressed clearly and concisely. However, although the course is aimed at L1 students and students must follow it in the L1 if the course is available in their section, it is possible to study the subject through the medium of the L2 when it is not available in their own L1. Many students have done this with great success and it can also be a way of developing advanced competence in the language of instruction.
- Readiness to read, listen to, analyse and produce texts, arguments and ideas...the "tools" of reflection need to be acquired together with the ability and willingness to use them.

Objectives

But it is not a question of learning theories or dates by heart... the idea is to improve our understanding of the world and ourselves. And additionally to learn to express ourselves effectively so that others can understand us.

Content

We learn to ask ourselves questions in four particular domains:

- Epistemology
 - Theory of knowledge
 - Theory of science
- Ethics
- Political philosophy
 - The state of nature and the social state
 - Democracy
 - Ideologies
- Anthropology
 - Existentialism
 - Essentialism

Assessment

The Baccalaureate exams

Students can choose between an oral and a written exam:

The oral exam - The pupil picks one random question from the four domains. The question is presented in the form of either a main question followed by guiding questions, or a quote followed by guiding questions, or a text followed by guiding questions. There will also be other documents (text – quote – image) to help achieve a structured answer. The oral exam, in which the pupil presents his results in form of an exposé and answers the questions, lasts 20 minutes.

The written exam - The questions are the same for all European schools and for all sections. The student answers a question from one of the four domains. The question is presented in the form of either a main question followed by guiding questions, or a quote followed by guiding questions, or a text followed by guiding questions. The students present their work in form of an essay.

Contact

For further information, please contact the Philosophy coordinator, Dr Peter Duncombe (peterduncombe@eursc.eu).

PHYSICS

Optional course
4 periods per week

This course is open to all pupils. However, it is recommended that pupils who wish to take this course have shown a particular interest in physics during their 5th year. Pupils choosing this course must also have a good level of mathematical ability. 5-period mathematics course is recommended.

Objectives

In this course, scientific competences with physical contents and concepts (fields, interactions, oscillations and waves, quantum physics) are taught, which cover thematically large parts of an essential study of physics at a university. The course builds on the learned and well-known content and competences and develops new ideas and methods. It is not only intended to impart formula knowledge and calculations. The students are also to be brought closer to the entirety of physics, i.e. also experimental work, historical and philosophical aspects, work in groups and with digital tools and modern methods of communication.

Content

In the 6th year course, the gravitational force and potential are investigated, and thus movements in the gravitational field are described and explained. Later, the course includes the electric field and its basics. This concept is then applied to capacitors. The magnetic field covers basics such as the field of a coil, Lorentz force and induction. Both mechanical and electromagnetic vibrations and waves with a focus on optics are treated. In quantum physics, the photoelectric effect, Compton effect, wave-particle duality and the Bohr's atomic model are investigated.

Assessment

The assessment is based on the competency-oriented attainment descriptors. This is to ensure that the assessment is versatile and multidimensional. Besides written tests, the attainment of competencies will be assessed through a variety of methods, which can include home assignments, laboratory reports, thesis or presentations.

Contact

For further information, please contact your Physics teacher.

POLITICAL SCIENCE

Complementary course
2 periods per week

This course is open to all students interested in the philosophies, foundational theories, diverse structures, practical functions and international relations which govern the (political) world in which we exist.

Conceptually rigorous, Political Science is deemed a university-level course requiring motivated, inquiring, reflective and balanced communicators.

Political Science aims to make a significant contribution to the development of future European (and global) citizens. By deepening and clarifying knowledge, learning relevant vocabulary, promoting a critical spirit and taking the initiative to broaden their awareness of the science of Politics, students prepare themselves to play an active role in future of the 21st Century world. Connections will be made with: History; (Political) Philosophy; Geography; Sociology; and, Economics.

Objectives

Over the course of S6 & S7, students should develop skills in:

- 1) **Gathering** and **sorting** political information;
- 2) **Analysing** and **evaluating** this information;
- 3) **Synthesising** information, in **applied** situations and **evaluating** these situations;
- 4) **Organising** and **expressing** ideas with **objective clarity** and **informed personal response**.

Content

- Democracy, Institutions & Government
- Power, the State, Sovereignty & Rights
- Different Forms of Political Regime
- The European Union
- Political Ideologies
- International Relations & Global Politics

Assessment

Political Science is a Complementary Course. It will **not** be assessed by Compo, PreBac or Bac exam.

A-Mark: attitude; attendance; class contribution; student's own efforts; classwork & homework.

B-Mark: FOUR assessments over the course of each year (4 in S6; 4 in S7), undertaken in class.

Taking the Subject Further

This course is a respected asset for students with ambitions to study Politics, Philosophy, International Relations, Journalism, Law, Sociology and Economics (*as well as many other subjects*) at university. Political Science appeals to students who are already knowledgeable about aspects of the subject and also to those who wish to extend their intellectual horizons.

Contact

For further information, please contact the Political Science syllabus author and subject coordinator, Ms Ayesha Rana (ayesha.rana@teacher.eurasc.eu).

SOCIOLOGY

Complementary course
2 periods per week

All students can choose this course.

The course is normally taught in the working language if the numbers choosing it are enough.

Sociology is the scientific study of society and human behaviour: how 'we' shape society, and how society forms 'us'. The aim is to inspire students to become more literate about the societies in which they exist. This course seeks to empower students with the vocabulary and critical thinking skills to recognise and analyse the constructs and structures that form human society across a diverse spectrum. Looking at life through both micro and macro lenses, nothing is taken for granted in the Sociology classroom. "Why do we...?" is the foundation of the key questions in this fascinating and engaging exploration. Our journeys towards informed, open-minded and educated outlooks are often as enjoyable as the conclusive destinations we reach.

Objectives

- To broaden the experience and perspectives of the students
- To understand and analyse the social system and group behaviour
- To compare social behaviour across cultures
- To raise the students' awareness of current social issues

Content

- Sociological Approaches: Key Concepts, Ideas and Issues
- Social Development and Socialisation
- Major Sociological Paradigms and Theories
- Sociology and the Scientific Method
- Social Groups, Inequality and Stratification
- Families, Relationships and Households
- Education and Society
- Crime and Deviance (+ *Introduction to Criminology*)
- Culture and Identity
- Work, Poverty and Welfare
- Beliefs in Society
- Global Development
- The Media
- Health and Illness

Assessment

Sociology is a Complementary Course. It will not be assessed by Compo, PreBac or Bac exam.

A-Mark: attitude; attendance; class contribution; student's own effort and initiative; classwork & homework.

B-Mark: FOUR assessments over the course of each year (4 in S6; 4 in S7), undertaken in class.

Contact

For further information, please contact the Political Science and Sociology coordinator, Ms. Ayesha Rana (ayesha.rana@teacher.eurisc.eu).

SPORT

Complementary course
2 periods per week

This course is open to all students with a particular interest for the subject „sport“. Students should be open for several sports, because the course is based on different sports and activities. Students considering higher studies are recommended to take the „sport“ option to prepare the demanded pre tests of the university.

The complementary sport course engages students' interest in their physical development and further develops acquired competences through physical fitness, individual and team sports.

Objectives

- to get theoretical knowledge and background of the different sports
- to link theory and practice
- to apply the knowledge of health and fitness to plan and evaluate his own healthy lifestyle
- to turn ideas into action
- to organize his own learning within the subject

Content

- A. To develop an extra depth of knowledge, skills and attitude that students have acquired during their PE lessons in cycle 1 (S1-3) e.g. (ball games, swimming, gymnastics, athletics...).
- B. To introduce sports / activities which students have not experienced during their PE lessons in cycle 1 (S1-3) and cycle 2 (S4-5) e.g. (climbing, cycling, ice skating, canoe, self-defense, hiking, first aid, ...).

The teachers' and students' interest and local facilities may determine this.

Assessment

Practical tests in the different sports and activities.

Contact

For further information, please contact your Physical Education teacher or the Physical Education coordinators, Ms Carla Coppola (carla.coppola@teacher.eursec.eu).

TECHNICAL DRAWING

Complementary course
2 periods per week

Objectives

If you want to become an engineer / construction, interior design, architecture, mechatronics, mechanics / then this course is dedicated especially to you.

This subject will allow students to obtain acquire the following capacities:

1. Value the possibilities of technical drawing as an instrument for investigation, and understanding the universality of the objective language in the transmission and comprehension of information.
2. Develop the capacities which enable them to express with precision and objectivity the graphical solutions.
3. Understand the fundamentals of technical drawing to apply them to the reading and interpretation of plain designs and artistic products, and to elaborate reasoned solutions for geometrical problems both in the plane and in space.
4. Understand normalisation as the ideal conventionalism to simplify, not only production, but also communication, giving it a more universal character.
5. Integrate the activities of technical drawing in a cultural field where the relevance of aesthetic aspects is present, such as art, architectonic design, or industrial design
6. Understand and represent shapes, following the norms UNE and ISO
7. Understand that the diversity of plastic techniques improves the conventional conception of technical drawing.
8. Integrate the knowledge given by technical drawing into investigation processes, including scientific, artistic, or technological.
9. Encourage method and reasoning in drawing, as a means of transmission of scientific-technical ideas.
10. Develop skills which allow expressing graphical solutions with precision, clarity, and objectivity.
11. Use the specific instruments of technical drawing skilfully, and value the correct finishing of the drawing, as well as the improvements that diverse graphical techniques can introduce in representation.
12. Develop the skill to create sketches, to attain speed and precision in the graphical expression.
13. Relate the space to the plane, understanding the need to interpret the volume in the plane, through the systems of representation.
14. 3D modeling in Autocad 2021, Inventor 2021 and others

Content

The content is divided in three big THEMATIC BLOCS:

- I. GEOMETRIC DRAWING: Metric applied geometry
- II. DESCRIPTIVE GEOMETRY: Representation systems
- III. NORMALISATION

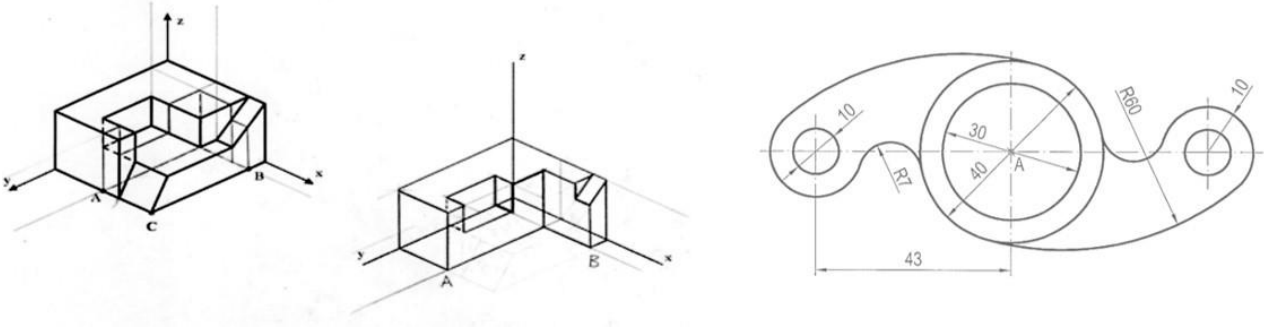
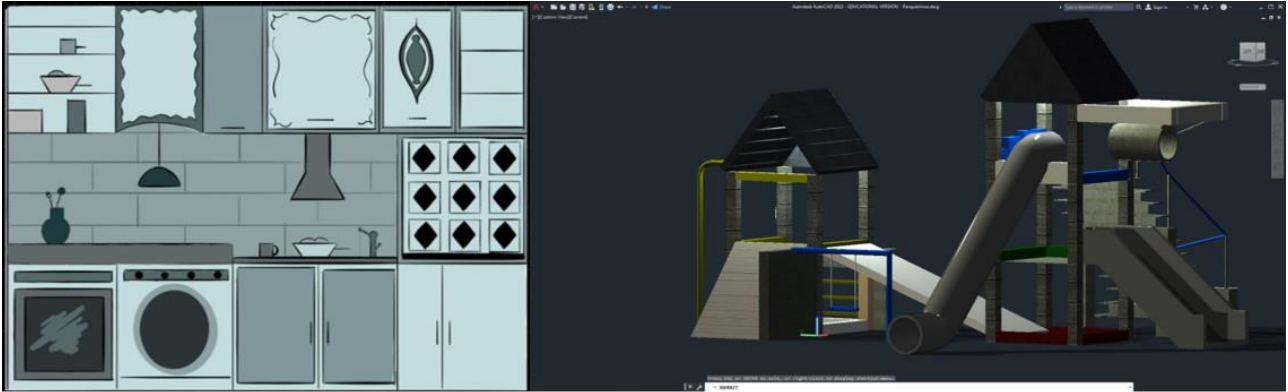

Assessment

Grade A in engineering drawing is based on continuous assessment of activity, workbook, class activity and project making.

The B grade is based on a variety of B tests in the semester that include conceptual content questions.

Contact

For further information, please contact Mr Tomasz Prokop (tomasz.prokop@teacher.eurasc.eu).